

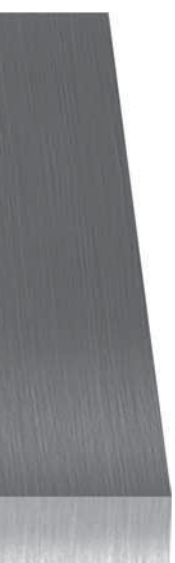

# Turnover Knives, Profile Knives, Knives



Product	Page
Turnover Knives, Profile Knives	6-1
Turnover Spurs	6-11
Turnover Knives	6-13
centering point	6-22
Mini Turnover Knives	6-23
Portable Planer Turnover Knives	6-25
Radius and Chamfering Turnover Knives / Profile Knives	6-26
Profile Knives / Turnover Knives	6-36
Profile Turnover Knives	6-47
Scraper Turnover Knives / Knives	6-50
Cup Knives	6-58
Saw Teeth	6-59
Planing Knives	6-60
Blanks	6-66

150511 / 150512 / 150515 / 150516 / 150518 / 150718

## Turnover Knives HW with 2 cutting edges

Product



Drawing

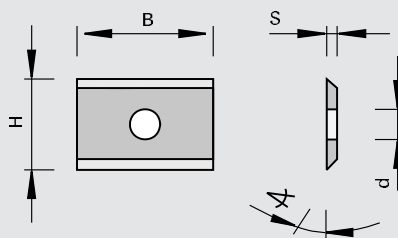

tungsten carbide [HW]

Machine / Application

Design

Advantages

Notes

- | Topline (polished face and micro-ground clearance angle)
- | cutting material: HW
- | HW HL Board 01 for wood-based panels and plastics
- | HW HL Board 02 for wood-based panels and plastics
- | HL Board 06 for wood-based panels, plastics, hard and soft woods
- | HL Board 05 for wood-based panels, plastics and hard woods
- | HL Solid 25 for hard and soft woods
- | HL Solid 25 Topline for hard and soft woods

- | long edge lives and optimum cutting quality in solid woods

- | packing unit: 10 pieces

B	H	S	Ø d	Wedge∠	LEUCODUR	Ident-No.
7,6	12	1.5	4	55	HL Board 05	052543
7,5	12	1.5	4	45	HL Solid 25	173473 o
9,6	12	1.5	4	55	HL Board 05	171163
10,5	12	1.5	4	55	HL Board 05	162636
11	12	1.5	4	55	HL Board 05	162637
13	12	1.5	4	55	HL Board 05	162638
15	12	1.5	4	55	HL Board 05	003081
15	12	1.5	4	45	HL Solid 25	173467 o
15,7	12	1.5	4	55	HL Board 05	163846
17	12	1.5	4	55	HL Board 05	162639
18	12	1.5	4	55	HL Board 05	162520
19	12	1.5	4	55	HL Board 05	164242
20	12	1.5	4	55	HL Board 01	180222
20	12	1.5	4	55	HL Board 02	176469
20	12	1.5	4	55	HL Board 06	178287
20	12	1.5	4	55	HL Board 05	003082
20	12	1.5	4	45	HL Solid 25	173468 o
20	12	1.5	4	45	HL Solid 25 Topline	176265
[mm]	[mm]	[mm]	[mm]	[°]		

150511 / 150512 / 150515 / 150516 / 150518 / 150718

## Turnover Knives HW with 2 cutting edges

Product

Drawing

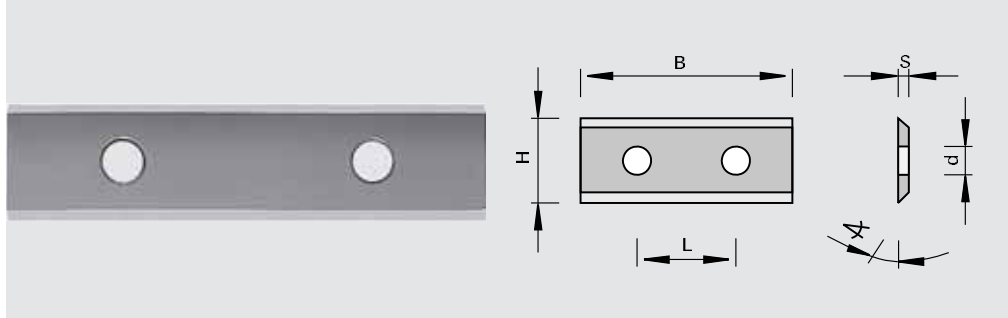
LEUCO  
DUR

tungsten carbide [HW]

Machine / Application

Design

- | Topline (polished face and micro-ground clearance angle)
- | cutting material: HW
- | HL Board 01 for wood-based panels and plastics
- | HL Board 02 for wood-based panels and plastics
- | HL Board 06 for wood-based panels, plastics, hard and soft woods
- | HL Board 05 for wood-based panels, plastics and hard woods
- | HL Solid 25 for hard and soft woods
- | HL Solid 25 Topline for hard and soft woods
- | HL Solid 30 for hard and soft woods

Advantages

- | long edge lives and optimum cutting quality in solid woods

Notes

- | packing unit: 10 pieces

B	H	S	Ø d	L	Wedge	LEUCODUR	Ident-No.
30	12	1.5	4	14	55	HL Board 01	180223
30	12	1.5	4	14	55	HL Board 02	176470
30	12	1.5	4	14	55	HL Board 06	178288
30	12	1.5	4	14	55	HL Board 05	003083
30	12	1.5	4	14	45	HL Solid 25	173469 o
30	12	1.5	4	14	45	HL Solid 25 Topline	176266
40	12	1.5	4	26	55	HL Board 02	182191 o
40	12	1.5	4	26	55	HL Board 05	164078
40	12	1.5	4	26	45	HL Solid 25	173470 o
40	12	1.5	4	26	45	HL Solid 25 Topline	176267
50	12	1.5	4	26	55	HL Board 01	180224
50	12	1.5	4	26	55	HL Board 02	176471
50	12	1.5	4	26	55	HL Board 06	178289
50	12	1.5	4	26	55	HL Board 05	003085
50	12	1.5	4	26	45	HL Solid 25 Topline	176268
60	12	1.5	4	26	55	HL Board 05	003086
60	12	1.5	4	26	45	HL Solid 25	173472 o
60	12	1.5	4	26	45	HL Solid 25 Topline	176269
80	13	2.2	4	59-61	55	HL Board 06	003087
80	13	2.2	4	59-61	45	HL Solid 25 Topline	181677
100	13	2.2	4	59-61	55	HL Board 06	003088
120	13	2.2	4	59-61	55	HL Board 06	003089
[mm]	[mm]	[mm]	[mm]	[mm]	[°]		

150513 / 150515 150518 / 150718

## Turnover Knives HW with 4 cutting edges

Product



Drawing

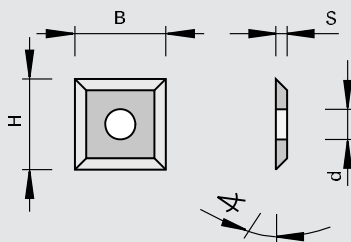

tungsten carbide [HW]

Machine / Application

Design

- | Topline (polished face and micro-ground clearance angle)
- | cutting material: HW
- | HL Board 03 for wood-based panels and plastics
- | HL Board 05 for wood-based panels, plastics and hard woods
- | HL Solid 25 Topline for hard and soft woods
- | HL Solid 30 for hard and soft woods

Advantages

- | long edge lives and optimum cutting quality in solid woods

Notes

- | packing unit: 10 pieces

B	H	S	Ø d	Wedge∠	LEUCODUR	Ident-No.
10,5	10,5	1,5	4	55	HL Solid 30	162316
12	12	1,5	4	55	HL Board 03	180820
12	12	1,5	4	55	HL Board 05	003080
12	12	1,5	4	45	HL Solid 25 Topline	176340
17	17	2	4	35	HL Board 05	162581
19	19	2	4	55	HL Board 05	162582
[mm]	[mm]	[mm]	[mm]	[°]		

150515

## Turnover Knives HW with 2 cutting edges, end sharpened

Product

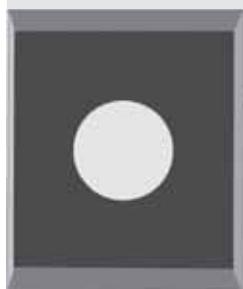

Drawing

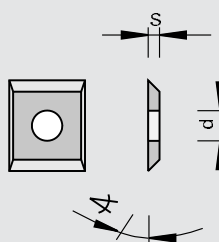

tungsten carbide [HW]

Machine / Application

Design

- | cutting material: HW
- | HL Board 05 for wood-based panels, plastics and hard woods

Advantages

Notes

- | packing unit: 10 pieces

B	H	S	Ø d	Wedge∠	LEUCODUR	Ident-No.
9	12	1,5	4	55	HL Board 05	167256
10	12	1,5	4	55	HL Board 05	165914
[mm]	[mm]	[mm]	[mm]	[°]		

150516 / 150513

Turnover Knives HW with 2 cutting edges, end sharpened

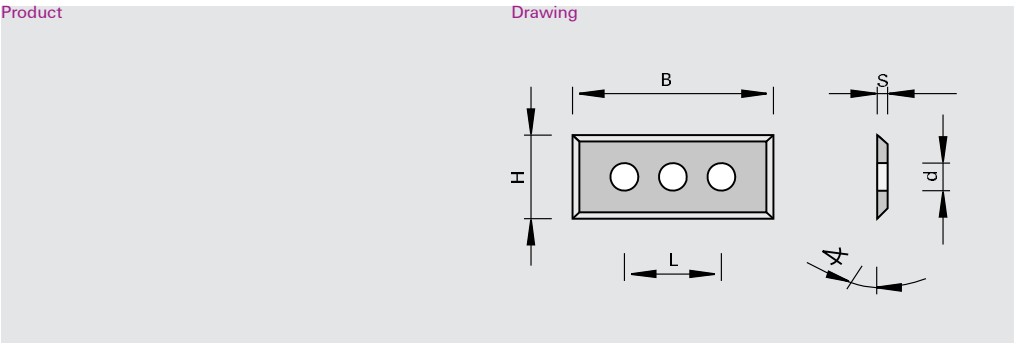

**LEUCO DUR**  
tungsten carbide [HW]

<b>Machine / Application</b>	<b>Design</b>	<b>Advantages</b>	<b>Notes</b>
	<ul style="list-style-type: none"> <li>  cutting material: HW</li> <li>  HL Board 06 for wood-based panels, plastics and hard woods</li> <li>  HW HL Board 03 for wood-based panels and plastics</li> </ul>		<ul style="list-style-type: none"> <li>  packing unit: 10 pieces</li> </ul>

B	H	S	Ø d	L	Wedge◀	LEUCODUR	Ident-No.
50	12	1.7	4	37	55	HL Board 06	179994
50	12	1.7	4	37	55	HL Board 03	182456
[mm]	[mm]	[mm]	[mm]	[mm]	[°]		

150515

Turnover Knives HW with 2 cutting edges and chamfer - HolzHer

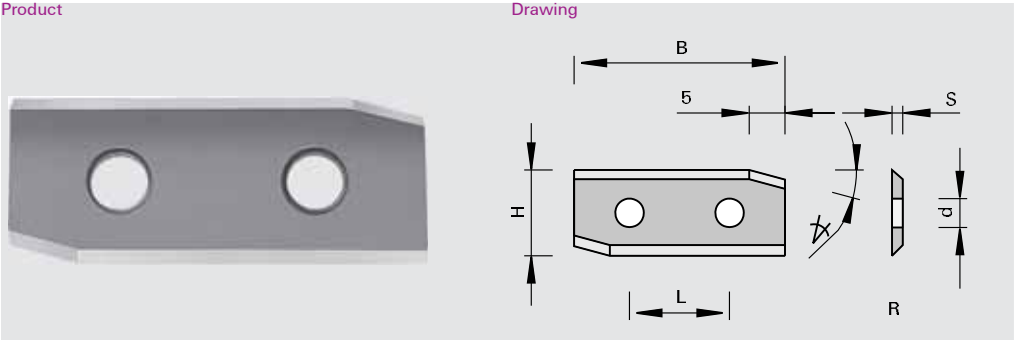

**LEUCO DUR**  
tungsten carbide [HW]

<b>Machine / Application</b>	<b>Design</b>	<b>Advantages</b>	<b>Notes</b>
<ul style="list-style-type: none"> <li>  machines HOLZ-HER</li> <li>  for use in edge banding / jointing cutterheads</li> </ul>	<ul style="list-style-type: none"> <li>  grinding angle 55 degrees</li> <li>  cutting material: HW</li> <li>  HL Board 06 for wood-based panels, plastics and hard woods</li> </ul>		<ul style="list-style-type: none"> <li>  packing unit: 10 pieces</li> </ul>

Chamfer◀	B	H	S	Ø d	L	Ident-No. [L]	Ident-No. [R]
15	29,5	12	1.5	4	14	160118	160618
[°]	[mm]	[mm]	[mm]	[mm]	[mm]		

150518

### Turnover Knives HW with 2 cutting edges, edge bevel - Brandt

Product

Drawing

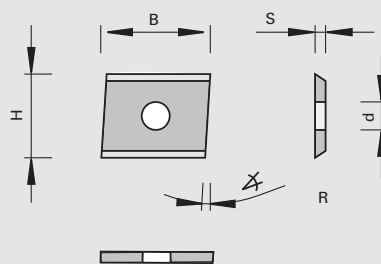

tungsten carbide [HW]

Machine / Application

for use in V-grooving cutterheads and prism cutterheads

Design

grinding angle 55 degrees  
cutting material: HW  
HL Solid 25 for hard and soft woods

Advantages

Notes

packing unit: 10 pieces

B	H	S	Ø d	Clearance $\sphericalangle 1$	Ident-No. [L]	Ident-No. [R]
15,0	14,3	2,5	6,3	6	184263	184262
[mm]	[mm]	[mm]	[mm]	[°]		

150515

### Turnover Knives HW with 2 cutting edges, edge bevel and end sharpened

Product

Drawing

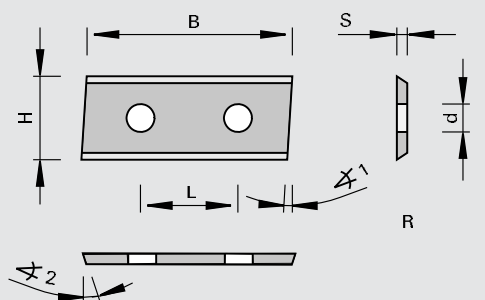

tungsten carbide [HW]

Machine / Application

for use in V-grooving cutterheads and prism cutterheads

Design

grinding angle 55 degrees  
cutting material: HW  
HL Board 05 for wood-based panels, plastics and hard woods

Advantages

Notes

packing unit: 10 pieces

B	H	S	Ø d	L	Clearance $\sphericalangle 1$	Clearance $\sphericalangle 2$	Ident-No. [L]	Ident-No. [R]
19,5	12	1,5	4		3,5	10	160626	160625
29,5	12	1,5	4	14	5		003119	003118
49,2	12	1,5	4	26	5		003121	003120
[mm]	[mm]	[mm]	[mm]	[mm]	[°]	[°]		

150513 / 150515

## Turnover Knives HW with 2 cutting edges, end sharpened

Product

Drawing

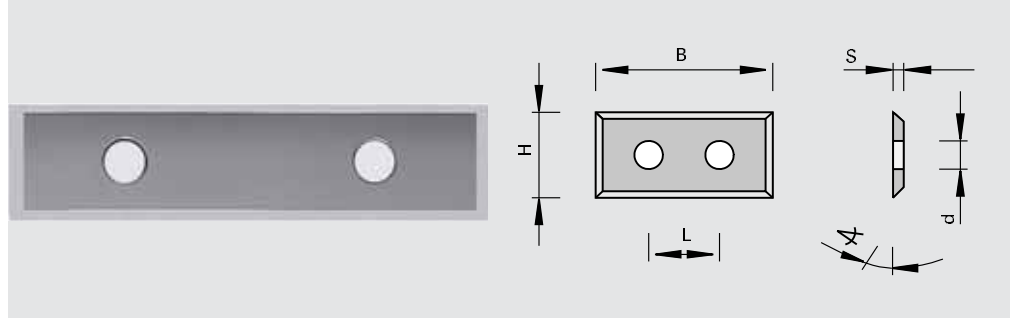
LEUCO  
DUR

tungsten carbide [HW]

Machine / Application

| for use in shank-type cutters

Design

| cutting material: HW  
 | HL Board 02 for wood-based panels and plastics  
 | HL Board 03 for wood-based panels and plastics  
 | HL Board 05 for wood-based panels, plastics and hard woods

Advantages

Notes

| packing unit: 10 pieces

B	H	S	Ø d	L	Wedge∠	LEUCODUR	Ident-No.
29,5	9	1.5	4	14	55	HL Board 03	180807
29,5	9	1.5	4	14	55	HL Board 05	180821
39,5	9	1.5	4	26	55	HL Board 05	180815
49,5	9	1.5	4	26	55	HL Board 03	180808
49,5	9	1.5	4	26	55	HL Board 05	180806
19,5	12	1.5	4		55	HL Board 05	183777
29,5	12	1.5	4	14	55	HL Board 02	181160
29,5	12	1.5	4	14	55	HL Board 05	180825
39,5	12	1.5	4	26	55	HL Board 05	171149
49,5	12	1.5	4	26	55	HL Board 05	180826
[mm]	[mm]	[mm]	[mm]	[mm]	[°]		

150513

## Turnover Knives HW with 2 cutting edges, end sharpened

Product

Drawing

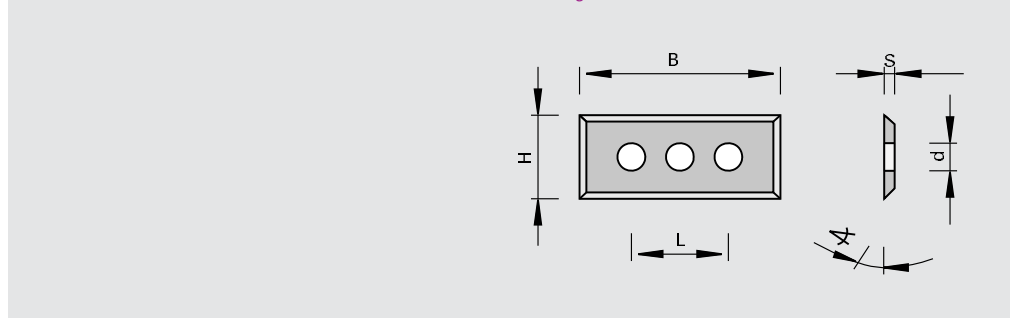
LEUCO  
DUR

tungsten carbide [HW]

Machine / Application

| for use in shank-type cutters

Design

| cutting material: HW  
 | HL Board 03 for wood-based panels and plastics

Advantages

Notes

| packing unit: 10 pieces

B	H	S	Ø d	L	Wedge∠	Ident-No.
50	9	1.5	3,7	37	55	181982
[mm]	[mm]	[mm]	[mm]	[mm]	[°]	



150515

### Turnover Knives HW with 2 cutting edges

Product

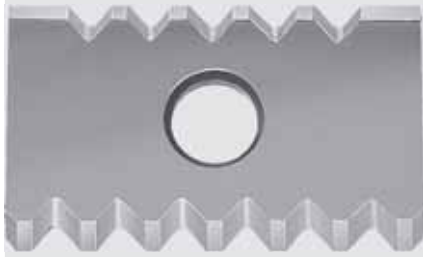

Drawing

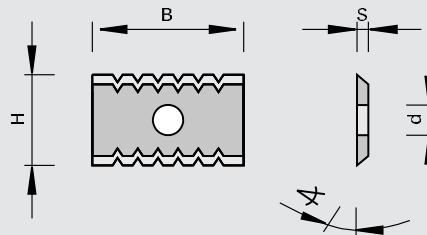

tungsten carbide [HW]

Machine / Application

| for use in hoggers

Design

| chip breakers for optimum cut division  
| cutting material: HW  
| HL Board 05 for wood-based panels, plastics and hard woods

Advantages

Notes

| packing unit: 10 pieces

B	H	S	Ø d	Wedge∠	Ident-No.
20 [mm]	12 [mm]	1.5 [mm]	4 [mm]	55 [°]	055905

150518

### Turnover Knives HW with 4 cutting edges

Product

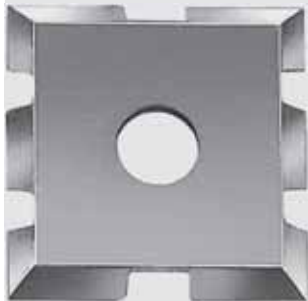

Drawing

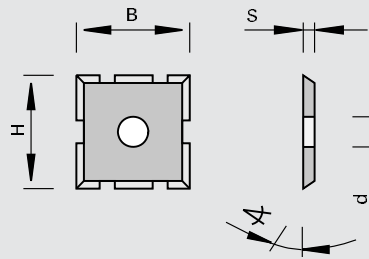

tungsten carbide [HW]

Machine / Application

Design

| chip breakers for optimum cut division  
| cutting material: HW  
| HL Solid 25 for hard and soft woods

Advantages

Notes

| packing unit: 10 pieces

B	H	S	Ø d	Wedge∠	Ident-No.
15 [mm]	15 [mm]	2 [mm]	4 [mm]	55 [°]	167873

150523 / 150525

## Profile Knives HW with 1 cutting edge, end sharpened

Product

Drawing

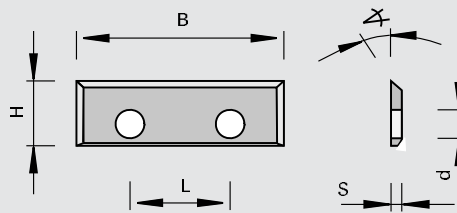
LEUCO  
DUR

tungsten carbide [HW]

Machine / Application

| for use in shank-type cutters

Design

| cutting material: HW  
 | HW HL Board 03 for wood-based panels and plastics  
 | HL Board 05 for wood-based panels, plastics and hard woods

Advantages

Notes

| packing unit: 10 pieces

B	H	S	Ø d	L	Wedge $\sphericalangle$	LEUCODUR	Ident-No.
16	7	1.5	3,4	7	55	HL Board 03	180262
23	7	1.5	3,4	14	55	HL Board 05	182697
28	7	1.5	3,4	14	55	HL Board 03	180260
[mm]	[mm]	[mm]	[mm]	[mm]	[°]		

150515

## Turnover Knives HW with 2 cutting edges

Product

Drawing

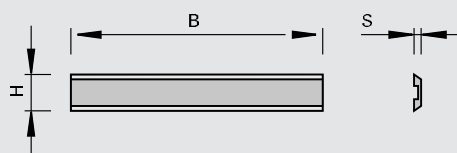
LEUCO  
DUR

tungsten carbide [HW]

Machine / Application

| for use in Leitz cutterheads

Design

| cutting material: HW HL Board 05 for wood-based panels, plastics and hard woods

Advantages

Notes

| packing unit: 10 pieces

B	H	S	Ident-No.
14,7	8	1.5	181504
19,7	8	1.5	181505
30	8	1.5	181506
35	8	1.5	181507
40	8	1.5	181508
50	8	1.5	181509
60	8	1.5	181510
80	8	1.5	181511
[mm]	[mm]	[mm]	

150518 / 150519

### Turnover Knives HW with 4 cutting edges

Product



Drawing

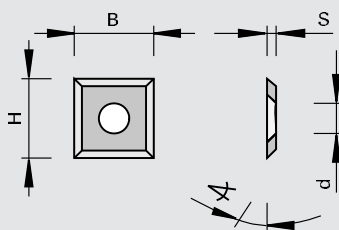

tungsten carbide [HW]

Machine / Application

l machines Hundegger  
l for use in cutterheads

Design

l cutting material: HW  
l HL Solid 60 for soft woods  
l HL Solid 30 for hard and soft woods

Advantages

Notes

l packing unit: 10 pieces

B	H	S	Ø d	Wedge∠	LEUCODUR	Ident-No.
21	21	5.5	7,3	40	HL Solid 30	180639
21	21	5.5	7,3	40	HL Solid 60	180638
[mm]	[mm]	[mm]	[mm]	[°]		

150518 / 150519

### Turnover Knives HW with 4 cutting edges and countersink

Product



Drawing

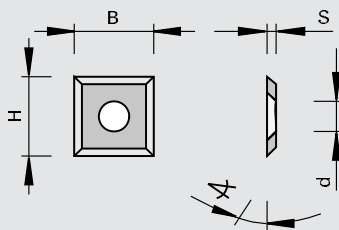

tungsten carbide [HW]

Machine / Application

l machines Homag, Fischer Brugg  
l for use in edge jointing cutterheads  
l for use in spiral cutterheads  
l for use in cutterheads

Design

Advantages

Notes

l packing unit: 10 pieces

B	H	S	Ø d	Wedge∠	LEUCODUR	Ident-No.
13,6	13.6	2	6,3	45	HL Solid 40	Fischer Brugg 163829
14,3	14.3	2.5	6,3	45	HL Solid 25	IMA 183828
14,3	14.3	2.5	6,3	55	HL Solid 25	Homag 170248
15	15	2.5	6,2	50	HL Solid 25	Chamfering Cutterhead 181243
15	15	2.5	6,4	60	HL Solid 25	with rounded edges (R=50 mm) 180454
20	14.3	2.5	6,3	55	HL Solid 15	Homag 168509
[mm]	[mm]	[mm]	[mm]	[°]		

150516

EcoKnife Turnover Knives HW with 2 cutting edges

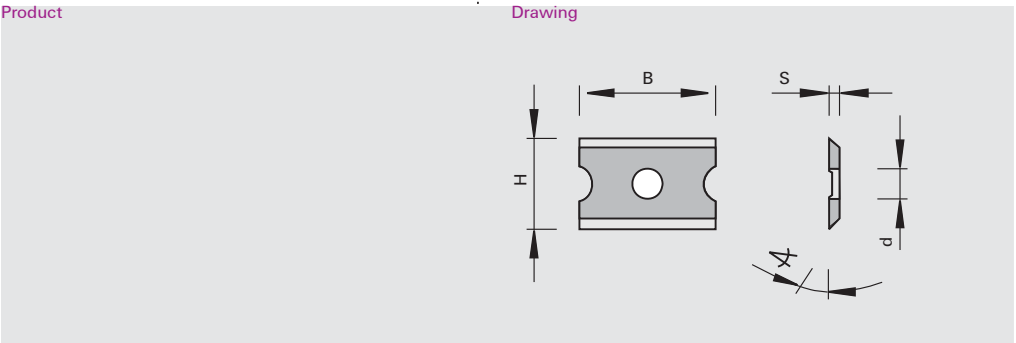

**LEUCO DUR**  
tungsten carbide [HW]

<b>Machine / Application</b>	<b>Design</b>	<b>Advantages</b>	<b>Notes</b>
	<ul style="list-style-type: none"> <li>  cutting material: HW</li> <li>  HL Board 06</li> <li>  less HW raw material charge</li> </ul>	<ul style="list-style-type: none"> <li>  long edge lives and optimum cutting quality in wood materials, plastics, hard and soft woods</li> <li>  turnover knife with less weight</li> <li>  less unbalance</li> </ul>	<ul style="list-style-type: none"> <li>  packing unit: 10 pieces</li> </ul>

B	H	S	Ø d	Wedge∠	Ident-No.
20 [mm]	12 [mm]	1.5 [mm]	4 [mm]	55 [°]	183569

150516

Turnover Knives with 2 cutting edges

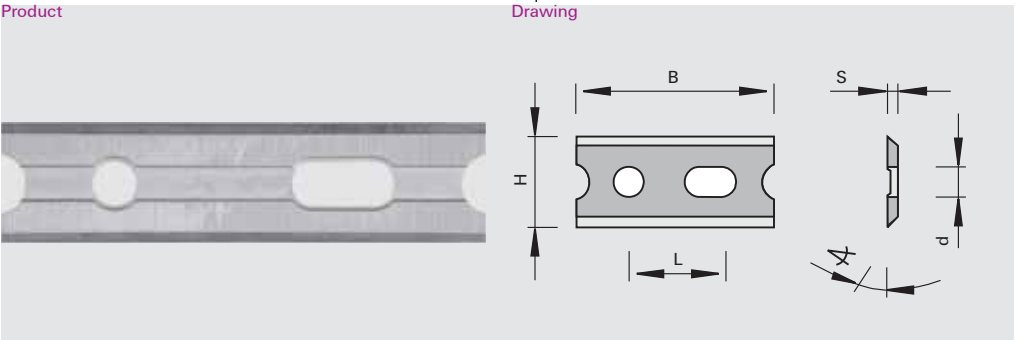

**LEUCO DUR**  
tungsten carbide [HW]

<b>Machine / Application</b>	<b>Design</b>	<b>Advantages</b>	<b>Notes</b>
	<ul style="list-style-type: none"> <li>  cutting material: HW</li> <li>  HL Board 06</li> <li>  less HW raw material charge</li> </ul>	<ul style="list-style-type: none"> <li>  long edge lives and optimum cutting quality in wood materials, plastics, hard and soft woods</li> <li>  turnover knife with less weight</li> <li>  less unbalance</li> </ul>	<ul style="list-style-type: none"> <li>  packing unit: 10 pieces</li> </ul>

B	H	S	Ø d	L	Wedge∠	Ident-No.
30 [mm]	12 [mm]	1.5 [mm]	4 [mm]	11-14 [mm]	55 [°]	183570
50 [mm]	12 [mm]	1.5 [mm]	4 [mm]	20-26 [mm]	55 [°]	183571

150558/132821

### Triangular Spur HW with 3 cutting edges

Product

Drawing

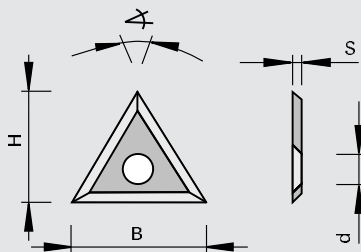

tungsten carbide [HW]

Machine / Application

| for use in Leitz cutterheads

Design

| cutting material: HW  
 | HL Solid 25 for hard and soft woods  
 | HL Solid 30 for hard and soft woods

Advantages

Notes

| packing unit: 10 pieces

B	H	S	Ø d	Corner∟	LEUCODUR	Ident-No.
22	19.05	2	6,5	60	HL Solid 25	180779
22,9	19.8	2.5	6,4	60	HL Solid 30	183685
[mm]	[mm]	[mm]	[mm]	[°]		

150553 / 150555 / 150759 / 150758

### Turnover Spurs HW with 4 cutting edges and countersink

Product

Drawing

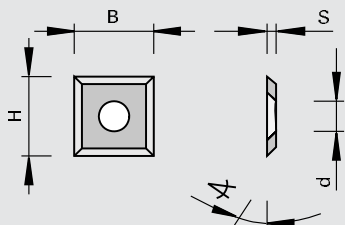

tungsten carbide [HW]

Machine / Application

| for use in cutterheads

Design

| Topline (polished face and micro-ground clearance angle)

Advantages

| significantly improved cutting edges  
 | excellent cutting quality especially in solid woods

Notes

| Ident-No. 167777 for scoring device of the HOLZ-HER vertical panel sizing saw  
 | \* marking for easier mounting  
 | packing unit: 10 pieces

B	H	S	Ø d	Wedge∟	LEUCODUR	Ident-No.
14	14	1.2	8,6	60	HL Solid 40	163701
14	14	1.2	8,6	60	HL Solid 40	HOLZ-HER 167777
14	14	2	6,3	60	HL Solid 25 Topline	176341
14	14	2	6,3	60	HL Solid 40	003079
14	14	2	6,3	60	HL Board 05	180954
14	14	2	6,3	60	HL Board 03	180646
[mm]	[mm]	[mm]	[mm]	[°]		

150558

## Turnover Spurs HW with 4 cutting edges and countersink - Lestro

Product



Drawing

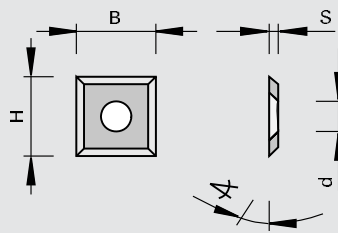

Machine / Application

l machines Lestro  
l for use in cutterheads

Design

Advantages

Notes

l packing unit: 10 pieces

B	H	S	Ø d	Wedge	LEUCODUR	Ident-No.
10,5	10,5	1,5	4	55	HL Solid 25	Lestro
[mm]	[mm]	[mm]	[mm]	[°]		

150558

## Turnover spurs HW

Product



Drawing

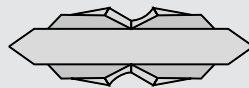

Machine / Application

l cutting edge with scoring cut  
l cutting material: HW  
l HL Solid 15 for wood-based panels, hard and soft woods

Design

Advantages

l chip-free hole edges thanks to cutting edge with scoring cut

Notes

l packing unit: 10 pieces

Dimension	LEUCODUR	Ident-No.
18x6x3,5	HL Board 15	181263
[mm]		

332121

## Turnover Knives HS with 2 cutting edges - Weing

Product

Drawing

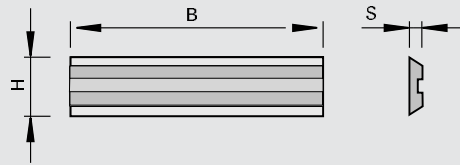

High Speed Steel [HS]

Machine / Application

for use in Weing planing cutterheads Centrolock for planing of soft woods

Design

cutting material: high speed steel (HS 18%) for soft woods

Advantages

high planing quality and long edge lives

Notes

packing unit: 2 pieces

B	H	S	Ident-No.
20	16	3	184334 o
60	16	3	184335 o
80	16	3	184336 o
100	16	3	184337 o
130	16	3	184338
150	16	3	184339 o
170	16	3	184340
180	16	3	184341 o
190	16	3	184342 o
210	16	3	184343 o
230	16	3	184344 o
240	16	3	184345
260	16	3	184346 o
270	16	3	184347 o
285	16	3	184331 o
310	16	3	184348 o
460	16	3	184349 o
[mm]	[mm]	[mm]	

150518

## Turnover Knives HW with 2 cutting edges - Weinig

Product

Drawing

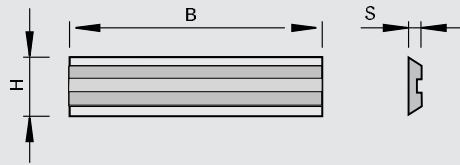

tungsten carbide [HW]

## Machine / Application

for use in Weinig planing cutterheads Centrolock for planing of glued soft woods, hard woods and MDF

## Design

cutting material: HW  
HL Solid 25 for hard and soft woods

## Advantages

high planing quality and long edge lives

## Notes

packing unit: 2 pieces

B	H	S	Ident-No.
20	16	3	181593 o
60	16	3	181594 o
80	16	3	181595 o
100	16	3	181596
130	16	3	181597
150	16	3	181598 o
170	16	3	181599
180	16	3	181600 o
190	16	3	181601 o
210	16	3	181602 o
230	16	3	181603 o
240	16	3	181604
260	16	3	181605 o
270	16	3	181606 o
310	16	3	181607 o
460	16	3	181608 o
[mm]	[mm]	[mm]	



332751

## Turnover Knives SP with 2 cutting edges - Tersa

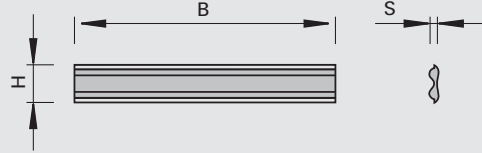
Product	Drawing	
		Alloyed Steel

Machine / Application	Design	Advantages	Notes
I for use in Tersa planing cutterheads	I SP - 13% chrome - special steel		I packing unit: 2 pieces

B	H	S	Ident-No.
60	10	2.3	175405 o
70	10	2.3	175406 o
80	10	2.3	175407 o
90	10	2.3	175408 o
100	10	2.3	175409 o
110	10	2.3	175410 o
120	10	2.3	175411 o
130	10	2.3	175412 o
140	10	2.3	175413 o
150	10	2.3	175414 o
160	10	2.3	175415 o
170	10	2.3	175416 o
180	10	2.3	175417 o
185	10	2.3	175418 o
190	10	2.3	175419 o
200	10	2.3	175420 o
210	10	2.3	175421 o
220	10	2.3	175422 o
230	10	2.3	175423 o
240	10	2.3	175424 o
250	10	2.3	175425 o
260	10	2.3	175426 o
265	10	2.3	175427 o
270	10	2.3	175428 o
280	10	2.3	175429 o
290	10	2.3	175430 o
300	10	2.3	175431 o
310	10	2.3	175432 o
315	10	2.3	175433 o
320	10	2.3	175434 o
330	10	2.3	175435 o
340	10	2.3	175436 o
350	10	2.3	175437 o
360	10	2.3	175438 o
370	10	2.3	175439 o
380	10	2.3	175440 o
390	10	2.3	175441 o
400	10	2.3	175442 o
410	10	2.3	175443 o
420	10	2.3	175444 o
430	10	2.3	175445 o
440	10	2.3	175446 o
450	10	2.3	175447 o
460	10	2.3	175448 o
[mm]	[mm]	[mm]	

B	H	S	Ident-No.
470	10	2.3	175449 o
480	10	2.3	175450 o
490	10	2.3	175451 o
500	10	2.3	175452 o
510	10	2.3	175453 o
520	10	2.3	175454 o
530	10	2.3	175455 o
540	10	2.3	175456 o
550	10	2.3	175457 o
560	10	2.3	175458 o
570	10	2.3	175459 o
580	10	2.3	175460 o
590	10	2.3	175461 o
600	10	2.3	175462 o
610	10	2.3	175463 o
620	10	2.3	175464 o
630	10	2.3	175465 o
635	10	2.3	175466 o
637	10	2.3	175467 o
640	10	2.3	175468
650	10	2.3	175469 o
[mm]	[mm]	[mm]	



332751

## Turnover Knives HS with 2 cutting edges - Tersa

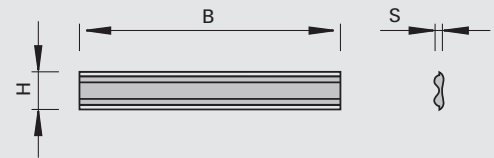
<b>Product</b>	<b>Drawing</b>	
		High Speed Steel [HS]

<b>Machine / Application</b>	<b>Design</b>	<b>Advantages</b>	<b>Notes</b>
for use in Tersa planing cutterheads	cutting material: HS		packing unit: 2 pieces

B	H	S	Ident-No.
60	10	2.3	175305 o
80	10	2.3	175307 o
90	10	2.3	175308 o
100	10	2.3	175309 o
110	10	2.3	175310 o
120	10	2.3	175311 o
130	10	2.3	175312 o
140	10	2.3	175313 o
150	10	2.3	175314 o
160	10	2.3	175315 o
170	10	2.3	175316 o
180	10	2.3	175317 o
185	10	2.3	175318 o
190	10	2.3	175319 o
200	10	2.3	175320 o
210	10	2.3	175321 o
220	10	2.3	175322 o
230	10	2.3	175323 o
240	10	2.3	175324 o
250	10	2.3	175325 o
260	10	2.3	175326 o
265	10	2.3	175327 o
270	10	2.3	175328 o
280	10	2.3	175329 o
300	10	2.3	175331 o
310	10	2.3	175332
320	10	2.3	175334 o
330	10	2.3	175335 o
350	10	2.3	175337 o
360	10	2.3	175338 o
400	10	2.3	175342 o
410	10	2.3	175343
420	10	2.3	175344 o
430	10	2.3	175345 o
450	10	2.3	175347 o
500	10	2.3	175352 o
510	10	2.3	175353
520	10	2.3	175354
530	10	2.3	175355 o
540	10	2.3	175356 o
610	10	2.3	175363 o
630	10	2.3	175365
635	10	2.3	175366 o
640	10	2.3	175368
[mm]	[mm]	[mm]	

B	H	S	Ident-No.
650	10	2.3	175369 o
[mm]	[mm]	[mm]	

132751

## Turnover Knives HW with 2 cutting edges - Tersa

Product

Drawing

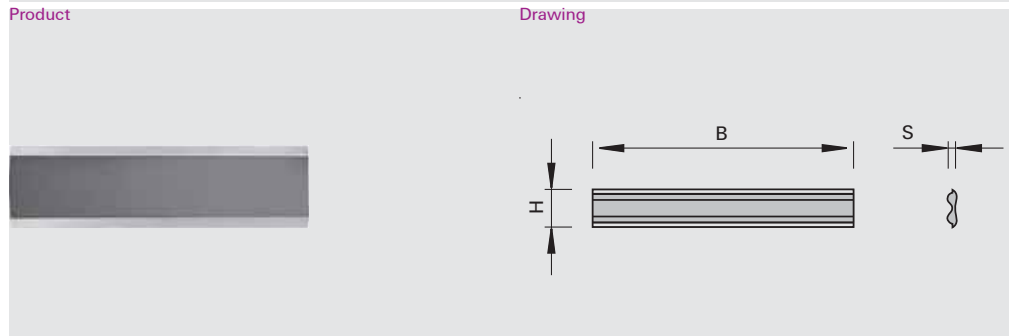
LEUCO  
DUR

tungsten carbide [HW]

Machine / Application

for use in Tersa planing  
cutterheads

Design

cutting material: HW

Advantages

Notes

a cutting length of more than  
630 mm is reached by means  
of several knives

packing unit 2 pieces

B	H	S	Ident-No.
60	10	2.3	175205 o
70	10	2.3	175206 o
80	10	2.3	175207 o
90	10	2.3	175208 o
100	10	2.3	175209 o
110	10	2.3	175210 o
120	10	2.3	175211 o
130	10	2.3	175212 o
140	10	2.3	175213 o
150	10	2.3	175214 o
160	10	2.3	175215 o
170	10	2.3	175216 o
180	10	2.3	175217 o
185	10	2.3	175218 o
190	10	2.3	175219 o
200	10	2.3	175220 o
210	10	2.3	175221 o
220	10	2.3	175222 o
230	10	2.3	175223
240	10	2.3	175224 o
250	10	2.3	175225 o
260	10	2.3	175226 o
265	10	2.3	175227 o
270	10	2.3	175228 o
280	10	2.3	175229 o
290	10	2.3	175230 o
300	10	2.3	175231 o
310	10	2.3	175232 o
315	10	2.3	175233 o
320	10	2.3	175234 o
330	10	2.3	175235 o
340	10	2.3	175236 o
350	10	2.3	175237 o
360	10	2.3	175238 o
370	10	2.3	175239 o
380	10	2.3	175240 o
390	10	2.3	175241 o
[mm]	[mm]	[mm]	

B	H	S	Ident-No.
400	10	2.3	175242 o
410	10	2.3	175243 o
420	10	2.3	175244 o
430	10	2.3	175245 o
440	10	2.3	175246 o
450	10	2.3	175247 o
460	10	2.3	175248 o
470	10	2.3	175249 o
480	10	2.3	175250 o
490	10	2.3	175251 o
500	10	2.3	175252 o
510	10	2.3	175253
520	10	2.3	175254 o
530	10	2.3	175255 o
540	10	2.3	175256 o
550	10	2.3	175257 o
560	10	2.3	175258 o
570	10	2.3	175259 o
580	10	2.3	175260 o
590	10	2.3	175261 o
600	10	2.3	175262 o
610	10	2.3	175263 o
620	10	2.3	175264 o
630	10	2.3	175265 o
635	10	2.3	175266 o
640	10	2.3	175268 o
650	10	2.3	175269 o
[mm]	[mm]	[mm]	

332121

## Turnover Knives HS with 2 cutting edges - Centrostar, Centrofix, Quickfix

Product

Drawing

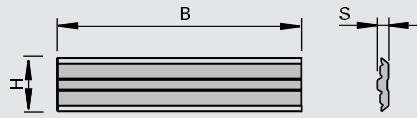

High Speed Steel [HS]

Machine / Application

for use in planing cutterhead systems Centrostar, Centrofix and Quickfix for planing of soft woods

Design

cutting material: HS for soft woods  
constant diameter

Advantages

high planing quality and long edge lives

Notes

packing unit 2 pieces

B	H	S	Ident-No.
80	12	2.7	182769 o
100	12	2.7	182770 o
130	12	2.7	182771 o
150	12	2.7	182772 o
170	12	2.7	182773 o
180	12	2.7	182774 o
190	12	2.7	182775 o
210	12	2.7	182776 o
230	12	2.7	182777 o
240	12	2.7	182778 o
310	12	2.7	182779 o
410	12	2.7	182780 o
510	12	2.7	182782 o
520	12	2.7	182781 o
640	12	2.7	182783 o
[mm]	[mm]	[mm]	

150518

## Turnover Knives HW with 2 cutting edges - Centrostar, Centrofix, Quickfix

Product

Drawing

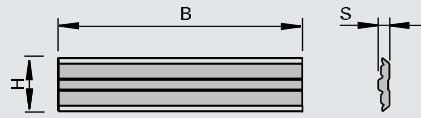

tungsten carbide [HW]

Machine / Application

for use in planing cutterhead systems Centrostar, Centrofix and Quickfix for planing of hard woods and MDF

Design

cutting material: HW  
HL Solid 25 for hard and exotic woods  
constant diameter

Advantages

high planing quality and long edge lives



Notes

a cutting length of more than 630 mm is reached by means of several knives  
packing unit 2 pieces

B	H	S	Ident-No.
100	12	2.7	182784 o
130	12	2.7	182785 o
150	12	2.7	182786 o
170	12	2.7	182787 o
180	12	2.7	182788 o
190	12	2.7	182789 o
210	12	2.7	182790 o
230	12	2.7	182791 o
240	12	2.7	182792 o
410	12	2.7	182793 o
510	12	2.7	182794 o
640	12	2.7	182795 o
[mm]	[mm]	[mm]	

165512

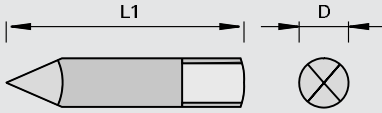

## Centering points HW

Product		Drawing		
				
				tungsten carbide [HW]
Machine / Application	Design	Advantages	Notes	
	<ul style="list-style-type: none"> <li>  with surface on shank for set screw</li> <li>  cutting material: HW</li> <li>  HL Solid 40 for hard and soft woods</li> </ul>		<ul style="list-style-type: none"> <li>  packing unit: 10 pieces</li> </ul>	
$\varnothing$ D	L1		Ident-No.	
3	33.5		162624	
[mm]	[mm]			

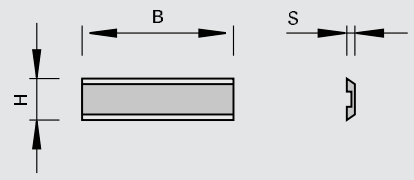

150535

### Mini Turnover Knives HW with 2 cutting edges



<b>Product</b>	<b>Drawing</b>	
		 tungsten carbide [HW]

<b>Machine / Application</b>	<b>Design</b>	<b>Advantages</b>	<b>Notes</b>
for use in shank-type cutter-heads	cutting material: HW   HL Board 05 for wood-based panels, plastics and hard woods		packing unit: 10 pieces

B	H	S	Ident-No.
12	5.5	1.1	162670
20	5.5	1.1	160623
40	5.5	1.1	160674
50	5.5	1.1	163572
[mm]	[mm]	[mm]	

150535

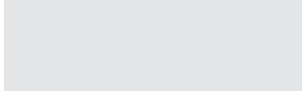
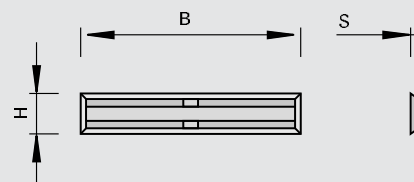
### Mini Turnover Knives HW with 2 cutting edges, end sharpened

<b>Product</b>	<b>Drawing</b>	
		 tungsten carbide [HW]

<b>Machine / Application</b>	<b>Design</b>	<b>Advantages</b>	<b>Notes</b>
for use in shank-type cutters	cutting material: HW   HL Board 05 for wood-based panels, plastics and hard woods		packing unit: 10 pieces

B	H	S	Ident-No.
12	5.5	1.1	168696
20	4.1	1.1	173480
20	5.5	1.1	173481
25	5.5	1.1	173793
30	5.5	1.1	173482
50	5.5	1.1	173483
[mm]	[mm]	[mm]	

150535

### Mini Turnover Knives HW with 2 cutting edges, end bevel

Product

Drawing

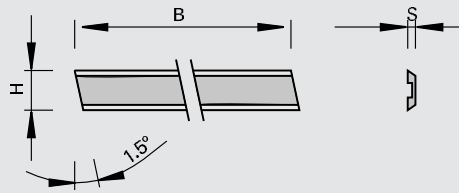

tungsten carbide [HW]

Machine / Application

- | CNC machining centers
- | for use in shank-type cutters

Design

- | cutting material: HW
- | HL Board 05 for wood-based panels, plastics and hard woods

Advantages

Notes

- | packing unit: 10 pieces

B	H	S	Ident-No.
39,8	5.5	1.1	163211 o
[mm]	[mm]	[mm]	



150549

### Portable Planer Turnover Knives HW with 2 cutting edges and edge bevel

Product

Drawing

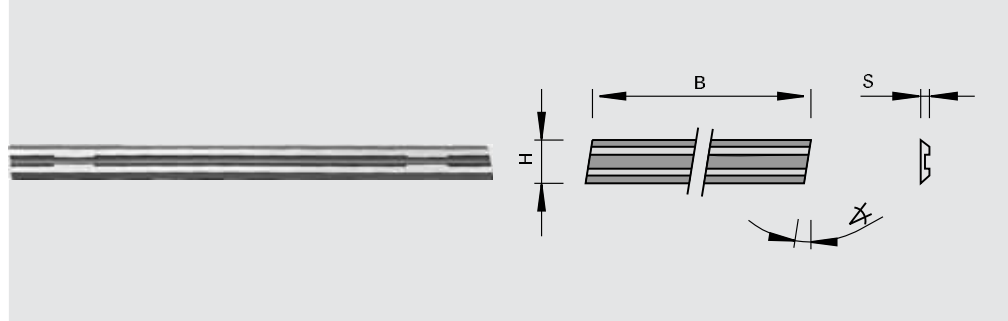

tungsten carbide [HW]

Machine / Application

| portable planers

Design

| cutting material: HW  
| HL Solid 40 for hard and soft woods

Advantages

Notes

| Ident-No. 166381 can only be used in the original ELU clamping element  
| packing unit: 10 pieces

B	H	S	Clearance <math>\sphericalangle 1</math>		Ident-No.
75,5	5.5	1.1	1.5	AEG HTH 75, Bosch 0590, P400, 1590, 1591, Festo REP 75, Haffner FH 222, HOLZ-HER 2223, 2286, 2320, Kress Jet Star 6701, Mafell HU 75, Metabo 6375, Scheer MH 80, MH 75/3, Skil 98 H	162439
75,7	5.5	1.2	8	Black&Decker DN 750	166079 o
80,5	5.9	1.2	8	ELU MFF 80	166381
82	5.5	1.1	3	AEG, Fein, Haffner, Hitachi, Mafell, Makita, Metabo, Bosch	165617
102	5.5	1.1	3	AEG EH 102, HB 750	419671 o
[mm]	[mm]	[mm]	[°]		

151545

### Radius Profile Knives HW with 2 cutting radii

Product



Drawing

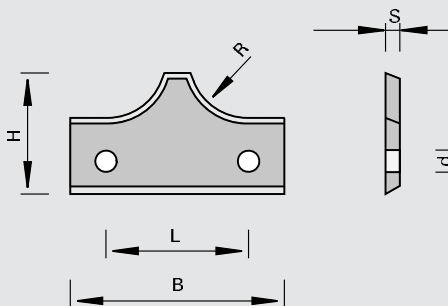

tungsten carbide [HW]

**Machine / Application**

for use in edge rounding cutterheads

**Design**

cutting material: HW  
HL Board 05 for wood-based panels, plastics and hard woods

**Advantages**

**Notes**

packing unit: 10 pieces

R	B	H	S	Ø d	L		Ident-No.
2	20,5	15	2	3	12	Homag	163062
3	20,8	15	2	3	12	Homag	163063
5	30	17	2	3	20	Homag	163065
4	20,8	15	2	3	12	Homag	163064 s
6	30,5	17	2	3	20	Homag	163066
8	30,5	17	2	3	20	Homag	163068
2	20,8	14.7	2	3	12	IMA	164166 s
3	20,8	14.7	2	3	12	IMA	164167 s
4	20,8	14.7	2	3	12	IMA	164168 s
5	30,5	16.5	2	3	20	IMA	164169 s
6	30,5	16.5	2	3	20	IMA	164170 s
7	30,5	16.5	2	3	20	IMA	164171 s
8	30,5	16.5	2	3	20	IMA	164172 s
[mm]	[mm]	[mm]	[mm]	[mm]	[mm]		

15 1545 / 15 1585

### Radius Profile Knives HW with 2 cutting radii and bottom chamfer

Product



Drawing

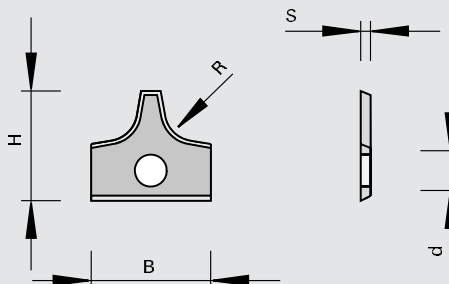

tungsten carbide [HW]

Machine / Application

for use in edge rounding cutterheads

Design

cutting material: HW  
HL Board 05 for wood-based panels, plastics and hard woods

Advantages

Notes

packing unit: 10 pieces

R	B	H	S	Ø d	Ident-No.
1,5	16	17.5	2	4,4	176583
2	12	12	1.5	4	170340
2	16	15.5	2	4,4	182087
2	16	17.5	2	4,4	163489
2,5	16	17.5	2	4,4	171178
3	12	12	1.5	4	170341
3	16	17.5	2	4,4	163490
4	16	17.5	2	4,4	163491
5	16	17.5	2	4,4	163492
[mm]	[mm]	[mm]	[mm]	[mm]	

15 1545 / 15 1585

### Radius Profile Knives HW with 2 cutting radii

Product

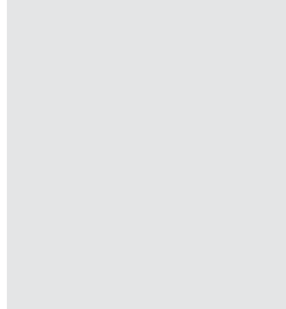

Drawing

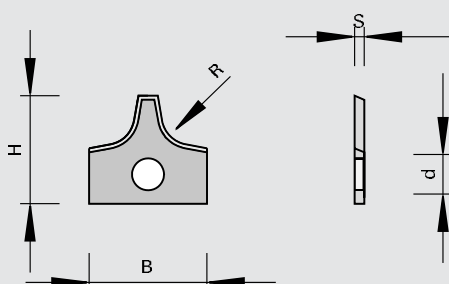

tungsten carbide [HW]

Machine / Application

for use in edge rounding cutterheads

Design

cutting material: HW  
HL Board 05 for wood-based panels, plastics and hard woods

Advantages

Notes

packing unit: 10 pieces

R	B	H	S	Ø d	Ident-No.
2	12	13	2	5	177033
2,5	12	13	2	4	173707
3	12	13	2	5	177032
6	24	22	2	4,4	170258
8	24	22	2	4,4	170260
9	24	22	2	4,4	170261
[mm]	[mm]	[mm]	[mm]	[mm]	

151545 / 151585

### Radius Profile Knives HW with 2 cutting radii and bottom chamfer - IMA, Wilmsmayer, Torwegge

Product



Drawing

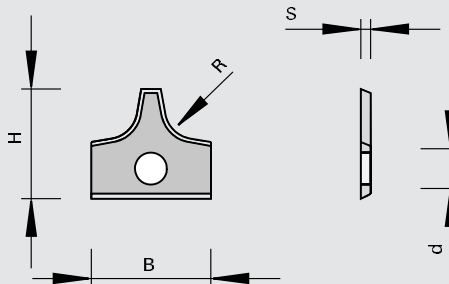

tungsten carbide [HW]

Notes

packing unit: 10 pieces

Machine / Application

machines IMA, Wilmsmayer, Torwegge  
for use in scraper holders

Design

cutting material: HW  
HL Board 05 for wood-based panels, plastics and hard woods

Advantages

R	B	H	S	Ø d	Ident-No.
2	16	17.5	2	3	173475
2,5	16	17.5	2	3	173476 s
3	16	17.5	2	3	173477
4	16	17.5	2	3	173478
5	16	17.5	2	3	173479
[mm]	[mm]	[mm]	[mm]	[mm]	

151545 / 151585

### Radius Profile Knives HW with 2 cutting radii and bottom chamfer - Brandt

Product



Drawing

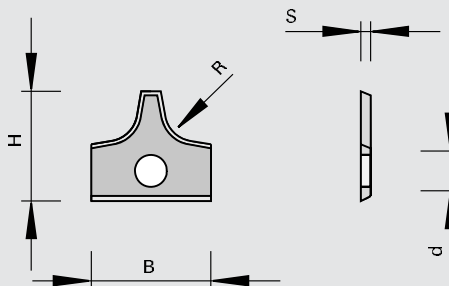

tungsten carbide [HW]

Notes

packing unit: 10 pieces

Machine / Application

copying-unit Brandt  
for use in edge rounding cutterheads

Design

cutting material: HW  
HL Board 05 for wood-based panels, plastics and hard woods

Advantages

R	B	H	S	Ø d	Ident-No.
2	16	17.5	2	4,4	180153
3	16	17.5	2	4,4	180154
[mm]	[mm]	[mm]	[mm]	[mm]	

15 1555

### Radius Profile Knives HW with 2 cutting radii

<b>Product</b>	<b>Drawing</b>	
		tungsten carbide [HW]

<b>Machine / Application</b>	<b>Design</b>	<b>Advantages</b>	<b>Notes</b>
<ul style="list-style-type: none"> <li>  for use in edge banding / rounding cutterheads</li> </ul>	<ul style="list-style-type: none"> <li>  cutting material: HW</li> <li>  HL Board 05 for wood-based panels, plastics and hard woods</li> <li>  5 degree profile run-out</li> </ul>		<ul style="list-style-type: none"> <li>  packing unit: 10 pieces</li> </ul>

R	B	H	S	Ø d	Ident-No.
2	13	16	2	4	162794
3	13	16	2	4	162795
4	13	16	2	4	162565
[mm]	[mm]	[mm]	[mm]	[mm]	

15 1555

### Radius Profile Knives HW with 2 cutting radii - IMA

<b>Product</b>	<b>Drawing</b>	
		tungsten carbide [HW]

<b>Machine / Application</b>	<b>Design</b>	<b>Advantages</b>	<b>Notes</b>
<ul style="list-style-type: none"> <li>  machines IMA</li> <li>  for use in edge banding / rounding cutterheads</li> </ul>	<ul style="list-style-type: none"> <li>  15 degree profile run-out</li> <li>  cutting material: HW</li> <li>  HL Board 05 for wood-based panels, plastics and hard woods</li> </ul>		<ul style="list-style-type: none"> <li>  packing unit: 10 pieces</li> </ul>

R	B	H	S	Ø d	Ident-No.
2	13	16	2	4	172713
3	13	16	2	4	172714
4	13	16	2	4	172715
[mm]	[mm]	[mm]	[mm]	[mm]	

15 1555

### Radius Profile Knives HW with 2 cutting radii

Product



Drawing

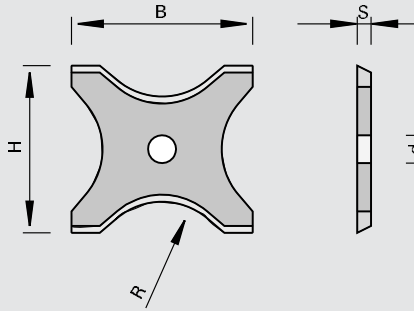

tungsten carbide [HW]

Machine / Application

| for use in edge banding / rounding cutterheads

Design

| 5 degree profile run-out  
| cutting material: HW  
| HL Board 05 for wood-based panels, plastics and hard woods

Advantages

Notes

| packing unit: 10 pieces

R	B	H	S	Ø d	Ident-No.
5	20	21	2	4	162566
6	20	21	2	4	162567
7	20	21	2	4	162568
8	20	21	2	4	162569
9	26	24	2	4	162796
10	26	24	2	4	162570
11	26	24	2	4	162571
12	26	24	2	4	162572
[mm]	[mm]	[mm]	[mm]	[mm]	

15 1555

### Radius Turnover Knives HW with 2 cutting radii

Product

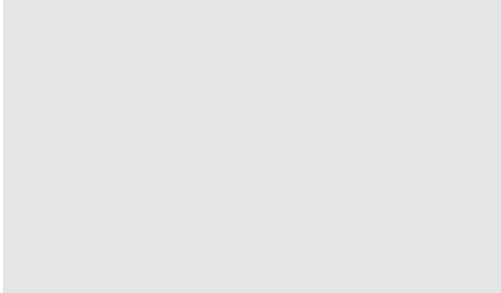

Drawing

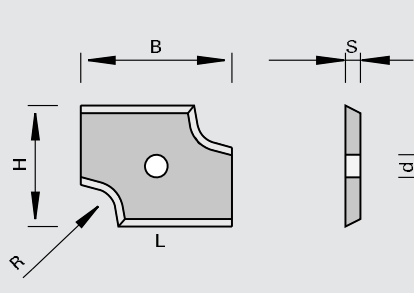

tungsten carbide [HW]

Machine / Application

| for use in edge rounding cutterheads

Design

| cutting material: HW  
| HL Board 05 for wood-based panels, plastics and hard woods

Advantages

Notes

| packing unit: 10 pieces

R	B	H	S	Ø d		Ident-No. [L]	Ident-No. [R]
3	20	16	2	3		168355	168356
2	30	14	2	4	Reich	177136	177135
2,5	30	14	2	4	Reich	177138 #	177137 #
3	30	14	2	4	Reich	177140	177139
[mm]	[mm]	[mm]	[mm]	[mm]			



15 1545

### Radius Profile Knives HW with 1 cutting radius

Product

Drawing

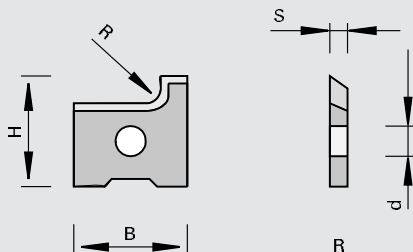

tungsten carbide [HW]

Machine / Application

for use in edge rounding cutterheads

Design

cutting material: HW  
HL Board 05 for wood-based panels, plastics and hard woods

Advantages

Notes

packing unit: 10 pieces

R	B	H	S	Ø d	Ident-No. [L]	Ident-No. [R]
2	12	18	2	4		172725
2	15	14.5	2	4	177317	177318
2	16,1	14	2	4	178219	178218
2	19,6	15.2	2	4	173817	173816
2,5	15	14.5	2	4	177319	177320
3	12	18	2	4		172726
3	15	14.5	2	4	177321	177322
3	16,1	14	2	4	178221	178220
3	19,6	15.2	2	4	173393	173392
[mm]	[mm]	[mm]	[mm]	[mm]		

15 1545 / 15 1586

### Radius Profile Knives HW with 1 cutting radius

Product

Drawing

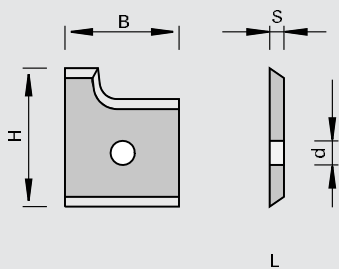

tungsten carbide [HW]

Machine / Application

for use in edge rounding cutterheads

Design

cutting material: HW  
HL Board 05 for wood-based panels, plastics and hard woods

Advantages

Notes

packing unit: 10 pieces

R	B	H	S	Ø d	LEUCODUR	Ident-No. [L]	Ident-No. [R]
2	12	14.5	2	4	HL Board 05	172142	172141
2,5	12	14.5	2	4	HL Board 05	171224	171223
3	12	14.5	2	4	HL Board 05	172144	172143
2,5	14,5	14.5	2	5	HL Board 06	181657	181658
[mm]	[mm]	[mm]	[mm]	[mm]			

151545

### Radius Profile Knives HW with 1 cutting radius

Product

Drawing

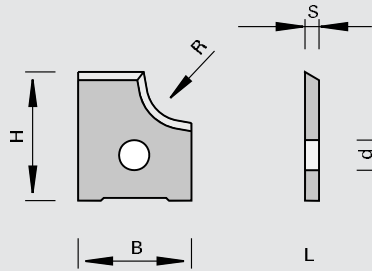

tungsten carbide [HW]

Machine / Application

| for use in rounding cutterheads

Design

| 5 degree profile run-out  
| cutting material: HW  
| HL Board 05 for wood-based panels, plastics and hard woods

Advantages

Notes

| packing unit: 10 pieces

R	B	H	S	Ø d	Ident-No. [L]	Ident-No. [R]
3	15	18.4	2	4	168272	168279
4	15	18.4	2	4	168273 #	168280 #
5	15	18.4	2	4	168274	168281
6	15	21.6	2	4	168286 #	168293 #
8	15	21.6	2	4	168288	168295
9	20	25.8	2	4	168301 s	168310 s
10	20	25.8	2	4	168302 s	168311 s
12	20	25.8	2	4	168304 s	168313
[mm]	[mm]	[mm]	[mm]	[mm]		

15 1545

### Radius Profile Knives HW with 1 cutting radius

Product

Drawing

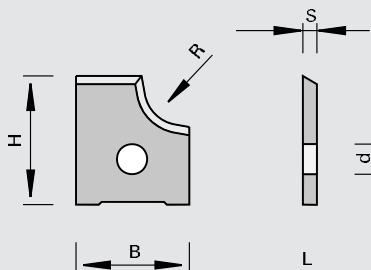

tungsten carbide [HW]

Machine / Application

Design

Advantages

Notes

- | 10 degree profile run-out
- | cutting material: HW
- | HL Board 05 for wood-based panels, plastics and hard woods
- | HL Board 06 for wood-based panels, plastics and hard woods

| packing unit: 10 pieces

R	B	H	S	Ø d	LEUCODUR	Ident-No. [L]	Ident-No. [R]
1,5	13	15	2	4	HL Board 06	181954	181953
2	12	15	2	4	HL Board 06	177034	177038
2	13	15	2	4	HL Board 06	181956	181955
3	13	15	2	4	HL Board 06	181957	181958
4	14	17	2	4	HL Board 05	177036	177040
5	15	17	2	4	HL Board 05	177037	177041
[mm]	[mm]	[mm]	[mm]	[mm]			

15 1545

### Radius Profile Knives HW with 1 cutting radius - Homag

Product

Drawing

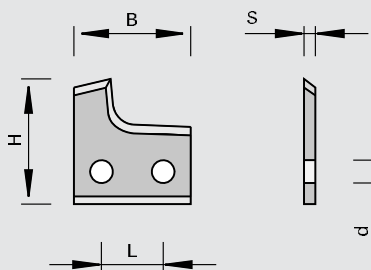

tungsten carbide [HW]

Machine / Application

Design

Advantages

Notes



- | machines Homag
- | for use in rounding cutterheads

- | 5 degree profile run-out
- | cutting material: HW
- | HL Board 05 for wood-based panels, plastics and hard woods

R	B	H	S	Ø d	L	Ident-No. [L]	Ident-No. [R]
10	21,8	20	2	3	12	163071	163072
12	21,8	20	2	3	12	163075	163076
[mm]	[mm]	[mm]	[mm]	[mm]	[mm]		

151545

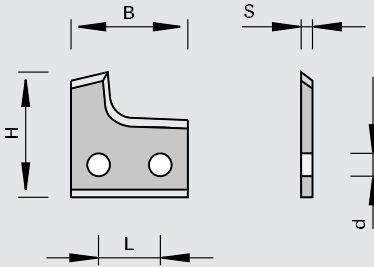
### Radius Profile Knives HW with 1 cutting radius - IMA



<b>Product</b> 	<b>Drawing</b> 	 tungsten carbide [HW]
---	--	--

<b>Machine / Application</b>   for use in rounding cutterheads	<b>Design</b>   5 degree profile run-out   cutting material: HW   HL Board 05 for wood-based panels, plastics and hard woods	<b>Advantages</b>	<b>Notes</b>   packing unit: 10 pieces
---	---	-------------------	---

R	B	H	S	Ø d	L	Ident-No. [L]	Ident-No. [R]
9	21,8	19,5	2	3	12	164173 s	164174 s
10	21,8	19,5	2	3	12	164175 s	164176 s
11	21,8	19,5	2	3	12	164177 s	164178 s
12	21,8	19,5	2	3	12	164179 s	164180 s
[mm]	[mm]	[mm]	[mm]	[mm]	[mm]		

151545

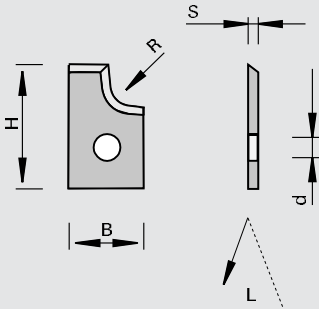
### Radius Profile Knives HW with 1 cutting radius - IMA

<b>Product</b>	<b>Drawing</b> 	 tungsten carbide [HW]
----------------	---	--

<b>Machine / Application</b>   machines IMA   for use in rounding cutterheads	<b>Design</b>   15 degree profile run-out   cutting material: HW   HL Board 05 for wood-based panels, plastics and hard woods	<b>Advantages</b>	<b>Notes</b>   packing unit: 10 pieces
---	--	-------------------	---

R	B	H	S	Ø d	Ident-No. [L]	Ident-No. [R]
2	12	18	2	5	180174	180173
3	12	18	2	5	180176	180175
[mm]	[mm]	[mm]	[mm]	[mm]		

15 1545

### Chamfering Knives HW with 2 cutting radii

Product



Drawing

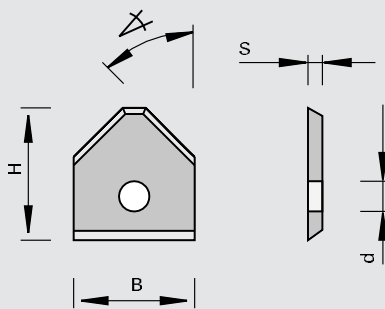

tungsten carbide [HW]

Machine / Application

for use in edge rounding cutterheads

Design

cutting material: HW  
HL Board 05 for wood-based panels, plastics and hard woods

Advantages

Notes

Ident-No. 180792 for Modula  
packing unit: 10 pieces

Chamfer $\sphericalangle$	B	H	S	Ø d	Ident-No.
45	12	12	1.5	4	180792
45	12	12	1.5	4	171190
45	16	17.5	2	3	169292
45	16	17.5	2	4,3	170329
[°]	[mm]	[mm]	[mm]	[mm]	

15 1545 / 15 1546

### Chamfering Knives HW with 1 cutting radius

Product

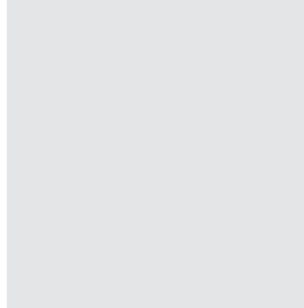

Drawing

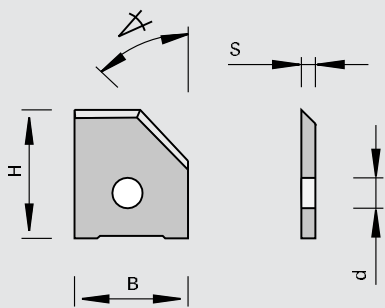

tungsten carbide [HW]

Machine / Application

machining centers Homag  
for use in chamfering cutterheads

Design

cutting material: HW  
HL Board 05 for wood-based panels, plastics and hard woods  
HL Board 06 for wood-based panels, plastics and hard woods

Advantages

Notes

packing unit: 10 pieces

Chamfer $\sphericalangle$	B	H	S	Ø d	LEUCODUR	Ident-No. [L]	Ident-No. [R]
5	12	16	2	5	HL Board 06	179174	179173
15	12	16	2	4	HL Board 05	177042	177045
30	13,5	16	2	4	HL Board 05	177043	177046
45	12	16	2	4	HL Board 05	177822	177823
45	15	16	2	4	HL Board 05	177044 s	177047 s
[°]	[mm]	[mm]	[mm]	[mm]			

151519

### Profile Turnover Knives HW for alucobond - HOLZ-HER

Product

Drawing

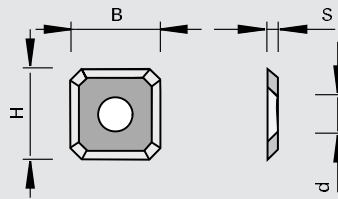

tungsten carbide [HW]

Machine / Application

vertical panel sizing saws  
HOLZ-HER  
for use in 90 degree Folding  
cutterhead Ident-No. 182616  
for the machining of alucobond

Design

cutting material: HW  
HL Solid 40 for hard and soft  
woods

Advantages

Notes

packing unit: 10 pieces

B	H	S	Ø d	∠	Ident-No.
14 [mm]	14 [mm]	2 [mm]	6,3 [mm]	90 [°]	182079

151516

### Profile Turnover Knives HW for alucobond - HOLZ-HER

Product

Drawing

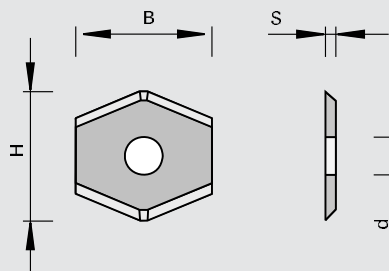

tungsten carbide [HW]

Machine / Application

vertical panel sizing saws  
HOLZ-HER  
for use in 135 degree Folding  
cutterhead Ident-No. 703144  
for the machining of alucobond

Design

cutting material: HW  
HL Board 06 for wood-based  
panels, plastics and hard  
woods

Advantages

Notes

packing unit: 10 pieces

B	H	S	Ø d	∠	Ident-No.
20 [mm]	18 [mm]	2 [mm]	5,7 [mm]	135 [°]	182080 s

15 1586

### Profile Knives HW - Brandt

Product

Drawing

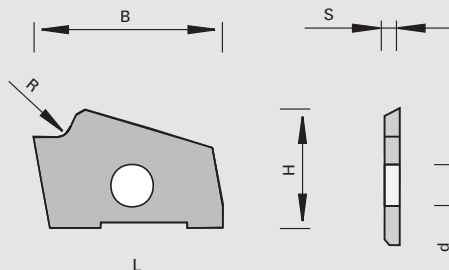

tungsten carbide [HW]

Machine / Application

edge banding machines Brandt since date of fabrication 2005 for use in rounding cutterheads with special chip removing design

Design

cutting material: HW  
HL Board 06 for wood-based panels, plastics and hard woods

Advantages

Notes

packing unit: 10 pieces

R	B	H	S	Ø d	Ident-No. [L]	Ident-No. [R]
1,5	22,32	14	2	5	183068 s	183067 s
2	22,32	14	2	5	182332	182331
2,5	22,32	14	2	5	182368	182367
3	22,32	14	2	5	182334	182333
[mm]	[mm]	[mm]	[mm]	[mm]		

15 1586

### Profile Knives HW - Brandt

Product

Drawing

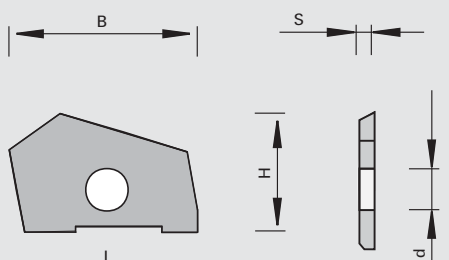

tungsten carbide [HW]

Machine / Application

edge banding machines Brandt since date of fabrication 2005 for use in rounding cutterheads with special chip removing design

Design

cutting material: HW  
HL Board 06 for wood-based panels, plastics and hard woods

Advantages

Notes

packing unit: 10 pieces

Chamfer	B	H	S	Ø d	Ident-No. [L]	Ident-No. [R]
45°	22,32	14	2	5	182667	182666
[°]	[mm]	[mm]	[mm]	[mm]		

150515 / 151545

### Profile Knives HW

Product



Drawing

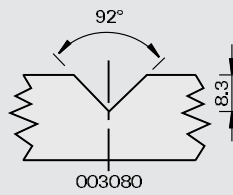

tungsten carbide [HW]

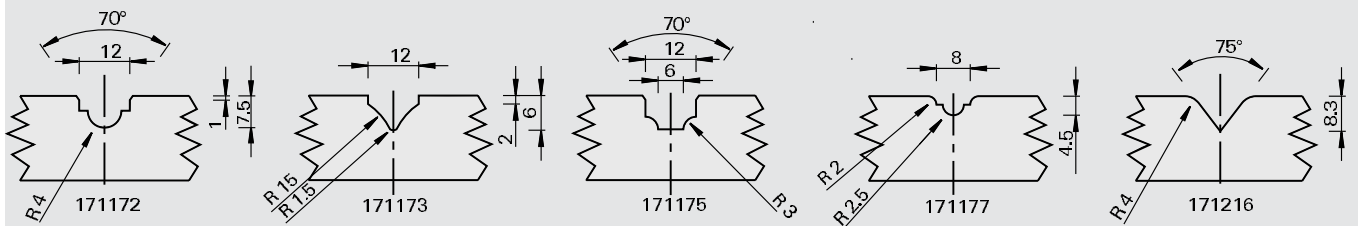

Machine / Application

for use in ornamental groove cutterheads

Design

cutting material: HW  
HL Board 05 for wood-based panels, plastics and hard woods

Advantages

Notes

packing unit: 10 pieces

B	H	S	Ø d	Ident-No.
12	12	1.5	4	003080
12	12	1.5	4	171177
11	12	1.5	4	171175
11	12	1.5	4	171172
12	12	1.5	4	171216
11	12	1.5	4	171173
[mm]	[mm]	[mm]	[mm]	

151548

### Profile Knives HW

Product

Drawing

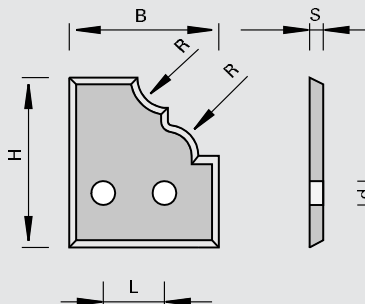

tungsten carbide [HW]

Machine / Application

for use in stile-and-rail profile cutterheads

Design

cutting material: HW  
HL Solid 25 for hard and soft woods

Advantages

Notes

packing unit: 10 pieces

R	B	H	S	Ø d	L	Ident-No.
4,5	19,3	24,5	2	3,5	11,2	165912
6,5	16,3	24,5	2	3,5	8,3	166127
[mm]	[mm]	[mm]	[mm]	[mm]	[mm]	



15 1548

## Profile Knives HW

Product

Drawing

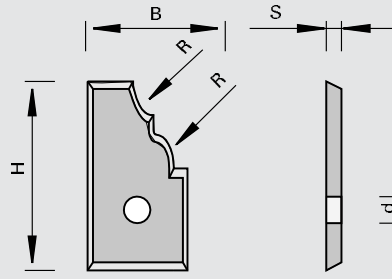

tungsten carbide [HW]

Machine / Application

| for use in stile-and-rail profile cutterheads

Design

| cutting material: HW  
| HL Solid 25 for hard and soft woods

Advantages

Notes

R	B	H	S	Ø d	L	Ident-No.
7	13,3	24.5	2	3,5		167469
[mm]	[mm]	[mm]	[mm]	[mm]	[mm]	

15 1548

## Profile Knives HW

Product

Drawing

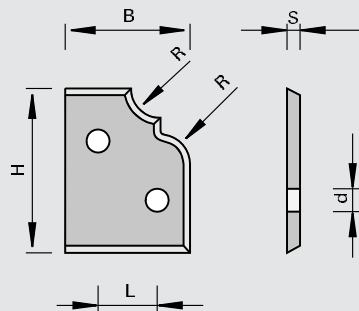

tungsten carbide [HW]

Machine / Application

| for use in panel-raising cutterheads

Design

| cutting material: HW  
| HL Solid 25 for hard and soft woods

Advantages

Notes

| packing unit: 10 pieces

R	B	H	S	Ø d	L	Ident-No.
4,5	19	25	2	3,5	9	165930
[mm]	[mm]	[mm]	[mm]	[mm]	[mm]	

151548

### Profile Knives HW

Product

Drawing

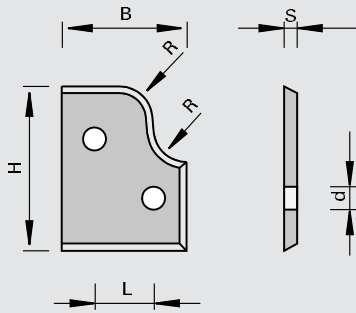

tungsten carbide [HW]

Machine / Application

for use in panel-raising cutterheads

Design

cutting material: HW  
HL Solid 25 for hard and soft woods

Advantages

Notes

packing unit: 10 pieces

R	B	H	S	Ø d	L	Ident-No.
5	19	25	2	3,5	9	165932
[mm]	[mm]	[mm]	[mm]	[mm]	[mm]	

151548

### Panel Raising Profile Knives HW

Product

Drawing

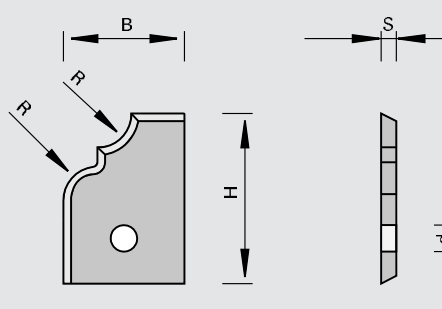

tungsten carbide [HW]

Machine / Application

for use in shank-type panel raising cutterheads

Design

cutting material: HW  
HL Solid 25 for hard and soft woods

Advantages

Notes

packing unit: 10 pieces

R	B	H	S	Ø d	Ident-No.
4,5	16	22,5	2	4	168883
[mm]	[mm]	[mm]	[mm]	[mm]	

15 1548

### Miter Glue Joint Profile Knives HW

Product



Drawing

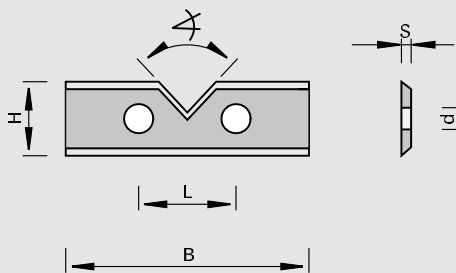

tungsten carbide [HW]

Machine / Application

for use in miter glue joint cutterheads

Design

cutting material: HW  
HL Solid 25 for hard and soft woods

Advantages

very accurate profiling for optimum glue joints

Notes

packing unit: 10 pieces

Chamfer	B	H	S	Ø d	L	Ident-No.
86°	39,5 [mm]	12 [mm]	1.5 [mm]	4 [mm]	26 [mm]	165916

15 1558

### Glue Joint Profile Turnover Knives HW

Product

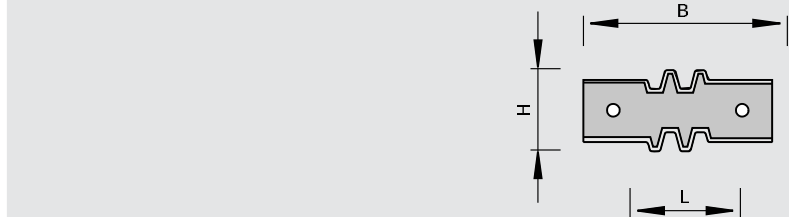

Drawing

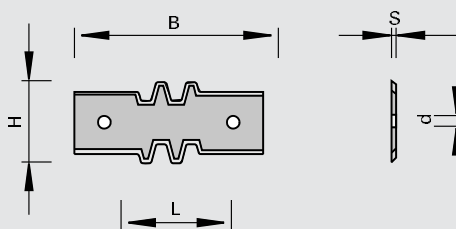

tungsten carbide [HW]

Machine / Application

for use in glue joint cutterheads

Design

cutting material: HW  
HL Solid 25 for hard and soft woods

Advantages

very accurate profiling for optimum glue joints

Notes

packing unit: 10 pieces

B	H	S	Ø d	L	Ident-No.
50 [mm]	21.6 [mm]	2 [mm]	4 [mm]	26 [mm]	165911

15 1558

### Glue Joint Profile Turnover Knives HW

Product

Drawing

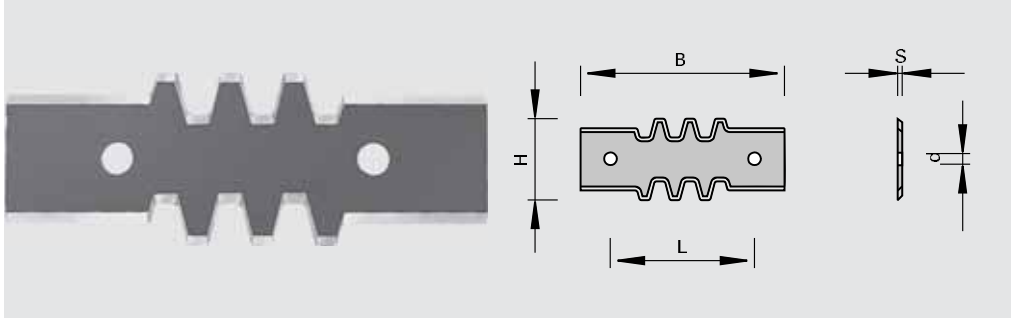

**LEUCO DUR**  
tungsten carbide [HW]

Machine / Application

| for use in glue joint cutterheads

Design

| cutting material: HW  
| HL Solid 25 for hard and soft woods

Advantages

| very accurate profiling for optimum glue joints

Notes

| packing unit: 10 pieces

B	H	S	Ø d	L	Ident-No.
60 [mm]	21.6 [mm]	2 [mm]	4 [mm]	32 [mm]	165909

15 1598

### Glue Joint Profile Turnover Knives HW Set

Product

Drawing

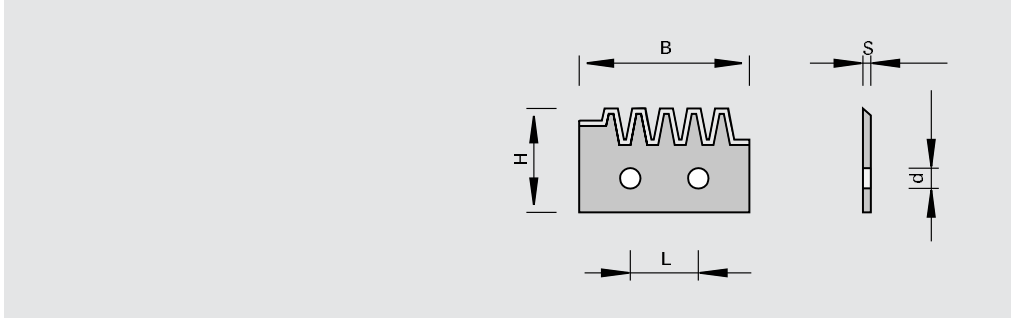

**LEUCO DUR**  
tungsten carbide [HW]

Machine / Application

| for use in adjustable glue joint cutterheads

Design

| cutting material: HW  
| HL Solid 25 for hard and soft woods

Advantages

| very accurate profiling for optimum glue joints

Notes

| set consists of 4 pieces  
Ident-No. 167977, 4 pieces  
Ident-No. 167976  
| packing unit: 10 pieces

B	H	S	Ø d	L	Ident-No.
42 [mm]	20 [mm]	2 [mm]	4 [mm]	26 [mm]	168240

132891

## Turnover Knife Holders - Ledinek Rotoles

Product



Drawing



tungsten carbide [HW]

Machine / Application

l planing machines Ledinek Rotoles  
l for LEUCODUR turnover knives straight and with chamfer

Design

l for mounting of LEUCODUR turnover knives 14 x 14 mm and 14.3 x 14.3 mm

Advantages

Notes

Ident-No.

for thicknesser (TOK 14x14x2) top	182082
for service planing rotor (TOK 14x14x2) bottom	182083
for thicknesser segments (TOK 14,3x14,3x2,5) top	182084
for service planing rotor segments (TOK 14,3x14,3x2,5) bottom	182085

Spare parts

Dimension

Class-No.

Ident-No.

Countersunk Flat Headed Screws	M5x9 T20 D=Ø9,3 [mm]	995125	827277
--------------------------------	-------------------------	--------	--------

150553 / 150555 / 150558 / 150559

## Profile Turnover Knives HW with 4 cutting edges - Ledinek Rotoles

Product



Drawing

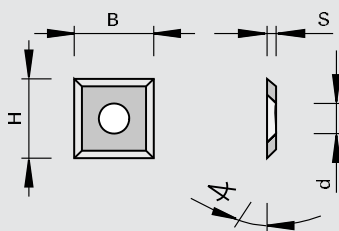

tungsten carbide [HW]

Machine / Application

l planing machines Ledinek Rotoles  
l for use in turnover knife holders for plain milling

Design

l cutting material: HW  
l HL Board 03 for wood-based panels and plastics  
l HL Board 05 for wood-based panels, plastics and hard woods  
l HL Solid 15 for wood-based panels, hard and soft woods  
l HL Solid 40 for hard and soft woods

Advantages

Notes

l packing unit: 10 pieces

B	H	S	LEUCODUR	Ident-No.
14	14	2	HL Solid 40	003079
14	14	2	HL Board 05	180954
14	14	2	HL Board 03	180646
14,3	14,3	2,5	HL Solid 25	170248
[mm]	[mm]	[mm]		

150558

### Profile Turnover Knives HW with 4 cutting edges and chamfer - Ledinek Rotoles

<b>Product</b>	<b>Drawing</b>	
		tungsten carbide [HW]

<b>Machine / Application</b>	<b>Design</b>	<b>Advantages</b>	<b>Notes</b>
<ul style="list-style-type: none"> <li>  planing machines Ledinek Rotoles</li> <li>  for use in turnover knife holders for plain milling</li> </ul>	<ul style="list-style-type: none"> <li>  cutting material: HW</li> <li>  HL Solid 15 for wood-based panels, hard and soft woods</li> <li>  HL Solid 25 for hard and soft woods</li> </ul>		<ul style="list-style-type: none"> <li>  packing unit: 10 pieces</li> </ul>

B	H	S	LEUCODUR	Ident-No. [L]	Ident-No. [R]
14	14	2	HL Solid 25	180933	180932
14,3	14.3	2.5	HL Solid 15	181144	181143
[mm]	[mm]	[mm]			

150558

### Profile Turnover Knives HW with 4 cutting edges and radius - Ledinek Rotoles

<b>Product</b>	<b>Drawing</b>	
		tungsten carbide [HW]

<b>Machine / Application</b>	<b>Design</b>	<b>Advantages</b>	<b>Notes</b>
<ul style="list-style-type: none"> <li>  planing machines Ledinek Rotoles</li> <li>  for use in turnover knife holders for plain milling</li> </ul>	<ul style="list-style-type: none"> <li>  cutting material: HW</li> <li>  HL Solid 15 for wood-based panels, hard and soft woods</li> <li>  HL Solid 25 for hard and soft woods</li> </ul>		<ul style="list-style-type: none"> <li>  packing unit: 10 pieces</li> </ul>

B	H	S	LEUCODUR	Ident-No. [L]	Ident-No. [R]
14	14	2	HL Solid 25	182442	182441
14,3	14.3	2.5	HL Solid 15	182444	182443
[mm]	[mm]	[mm]			

151527

## SuperProfiler Knives HW „Multi-Profile“

Product



Drawing

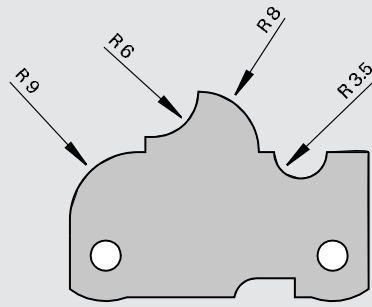

tungsten carbide [HW]

Machine / Application

table shapers  
for use in SuperProfiler  
cutterheads Ident-No. 167897  
and 167894

Design

cutting material: HW  
HL Solid 25 for hard and soft  
woods

Advantages

Notes

for cutting of various profiles  
in one or more steps  
profile examples see Technical  
Appendix

PU

Ident-No.

12

169273 s

[pc.]

## SuperProfiler „Multi-Profile“

### 1 Operation

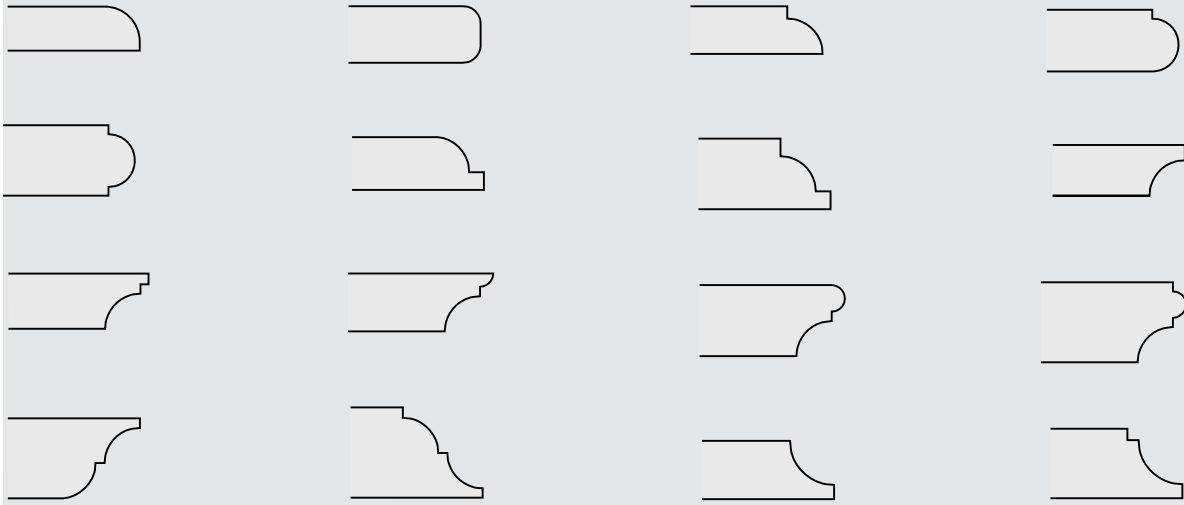

### 2 Operations

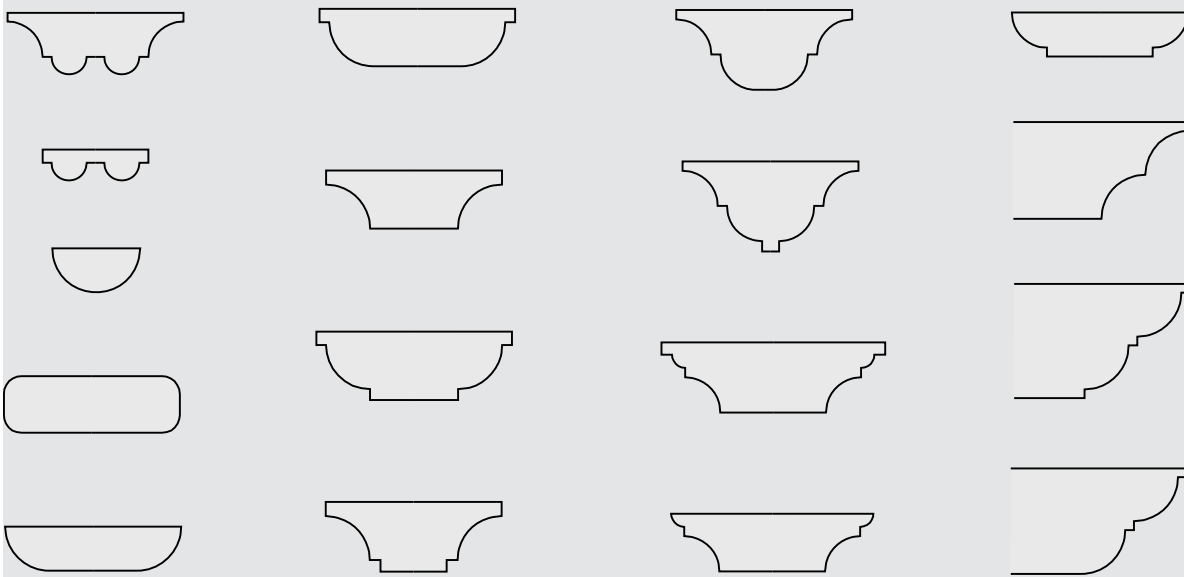

### Several operations

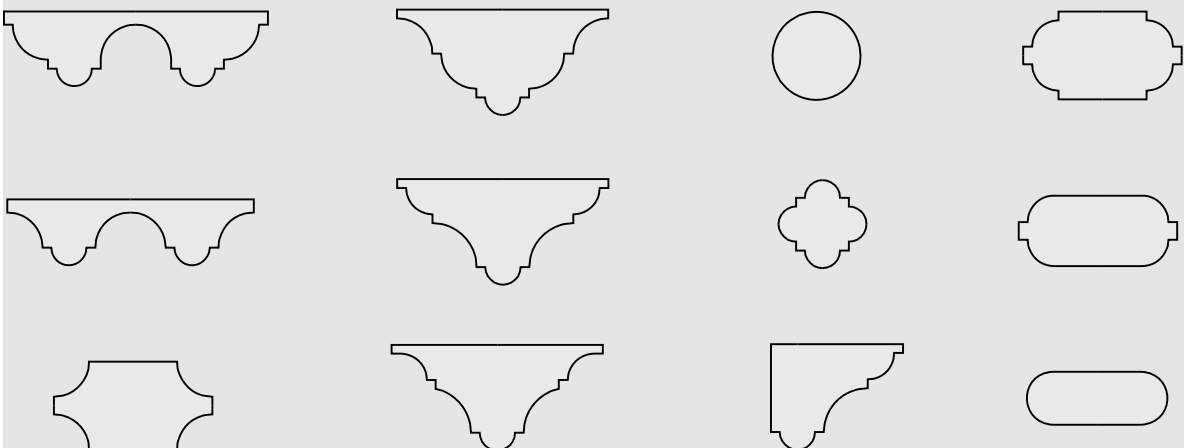



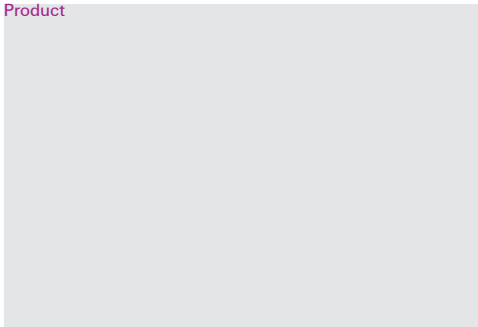
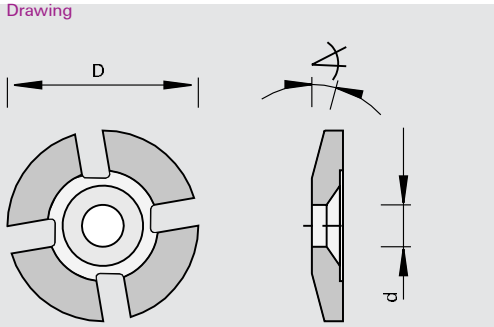

150508

### Grooving Turnover Knives HW with 4 cutting edges

Product		Drawing		 tungsten carbide [HW]	
					
<b>Machine / Application</b>   for use in miter glue joint cutterheads		<b>Design</b>   cutting material: HW   HL Solid 15 for wood-based panels, hard and soft woods		<b>Advantages</b>   very accurate profiling for optimum glue joints	
				<b>Notes</b>   in conjunction with profile knife Ident-No. 165916   packing unit: 10 pieces	
Chamfer $\sphericalangle$	$\varnothing D$	S	$\varnothing d$	Ident-No.	
15 [°]	25 [mm]	4.6 [mm]	5,4 [mm]	165918	

150578

### Chamfering Turnover Knives HW with 4 cutting edges

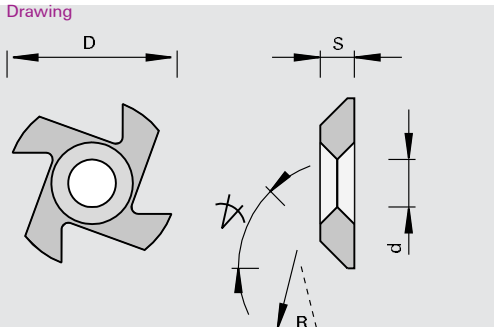
Product		Drawing		 tungsten carbide [HW]	
					
<b>Machine / Application</b>   for use in cutterheads for chamfering		<b>Design</b>   cutting material: HW   HL Solid 15 for wood-based panels, hard and soft woods		<b>Advantages</b>   very accurate profiling for optimum glue joints	
				<b>Notes</b>   packing unit: 10 pieces	
Chamfer $\sphericalangle$	$\varnothing D$	S	$\varnothing d$	Ident-No. [L]	Ident-No. [R]
45 [°]	25 [mm]	5 [mm]	7 [mm]	165966	165965

150508

### Grooving Turnover Knives HW with 4 cutting edges

Product

Drawing

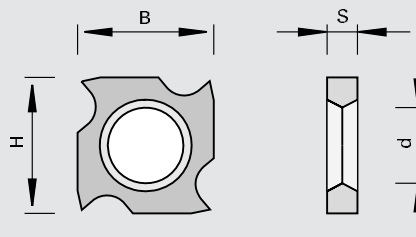

tungsten carbide [HW]

Machine / Application

| for use in grooving cutterheads

Design

| cutting material: HW  
| HL Solid 15 for wood-based panels, hard and soft woods

Advantages

Notes

| Ident-No. 163699 for groove width 4 mm  
| Ident-No. 165906 for groove width 5 mm  
| Ident-No. 169250 for groove width > 7 mm  
| packing unit: 10 pieces

B	H	S	Ø d	Ident-No.
18	18	1.95	10	163699
18	18	2.5	10	165906
18	18	3.7	10	169250
[mm]	[mm]	[mm]	[mm]	

150509

### Grooving Turnover Knives HW with 2 cutting edges

Product

Drawing

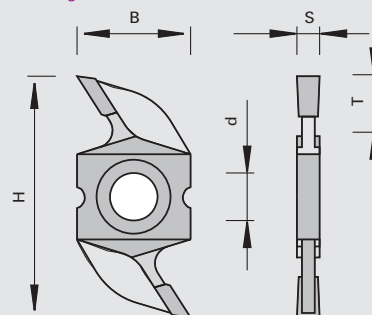

tungsten carbide [HW]

Machine / Application

| for use in cutterheads for grooving

Design

| bore countersunk 90 degrees  
| cutting material: HW  
| HL Solid 30 and HL Solid 40 for hard and soft woods

Advantages

| high accuracy thanks to radial positioning  
| more simple handling

Notes

| spacer rings for the adjustment of the rounding knives see chapter replacement parts  
| packing unit 10 pieces

B	H	S	Ø d	Tmax	LEUCODUR	Ident-No.
13	36	3.5	7,4	10	HL Solid 30	165968
16	34	3.2	6,7	8	HL Solid 40	183663
16	34	3.5	6,7	8	HL Solid 40	183664
16	34	4	6,7	8	HL Solid 40	183665
16	34	5	6,7	8	HL Solid 40	183666
[mm]	[mm]	[mm]	[mm]	[mm]		

150578

### Chamfering Turnover Knives HW with 4 cutting edges

<b>Product</b>	<b>Drawing</b>	
		tungsten carbide [HW]

<b>Machine / Application</b>	<b>Design</b>	<b>Advantages</b>	<b>Notes</b>
<ul style="list-style-type: none"> <li>for use in cutterheads for chamfering</li> </ul>	<ul style="list-style-type: none"> <li>cutting material: HW</li> <li>HL Solid 15 for wood-based panels, hard and soft woods</li> </ul>	<ul style="list-style-type: none"> <li>high accuracy thanks to radial positioning</li> <li>more simple handling</li> </ul>	<ul style="list-style-type: none"> <li>for clockwise and counter-clockwise rotation</li> <li>spacer rings for the adjustment of the chamfer knives see chapter replacement parts</li> <li>packing unit: 10 pieces</li> </ul>

Chamfer [°]	B [mm]	H [mm]	S [mm]	Ø d [mm]	Ident-No.
45	16	22	5	6,5	183668

150578

### Rounding Turnover Knives HW with 4 cutting edges



<b>Product</b>	<b>Drawing</b>	
		tungsten carbide [HW]

<b>Machine / Application</b>	<b>Design</b>	<b>Advantages</b>	<b>Notes</b>
<ul style="list-style-type: none"> <li>for use in cutterheads for rounding</li> </ul>	<ul style="list-style-type: none"> <li>cutting material: HW</li> <li>HL Solid 15 for wood-based panels, hard and soft woods</li> </ul>	<ul style="list-style-type: none"> <li>high accuracy thanks to radial positioning</li> <li>radii are interchangeable</li> <li>more simple handling</li> </ul>	<ul style="list-style-type: none"> <li>for clockwise and counter-clockwise rotation</li> <li>spacer rings for the adjustment of the rounding knives see chapter replacement parts</li> <li>packing unit: 10 pieces</li> </ul>

R [mm]	B [mm]	H [mm]	S [mm]	Ø d [mm]	Ident-No.
1,5	16	22	5	6,5	183669
2	16	22	5	6,5	183670
2,5	16	22	5	6,5	183671
3	16	22	5	6,5	183672

132891

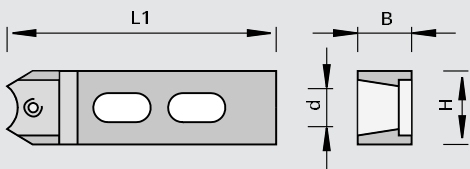
### Scrapper Holders - Homag, Reich, IMA

<b>Product</b>	<b>Drawing</b>	
		 tungsten carbide [HW]



<b>Machine / Application</b>	<b>Design</b>	<b>Advantages</b>	<b>Notes</b>
edge banding machines Homag, Reich   for installation of LEUCODUR radius-, chamfering- and scrapper turnover knives			

B	H	Ø d	L1		Ident-No.	
for R ≤ 5	15	16	6,5	131	Homag, Reich	169252
for R ≤ 5	22	14	6,5	118	Homag	179463
[mm]	[mm]	[mm]	[mm]			

Spare parts	Dimension	Class-No.	Ident-No.
Round Head Screws	M4x5,9 T15	995195	167966
Screwdrivers	T15	985730	163161
Screwdrivers	T15x80	985730	171188
	[mm]		

151555

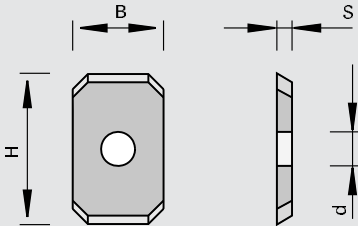
### Scrapper Turnover Knives HW with 2 cutting edges and chamfer - Homag, IMA, Reich

<b>Product</b>	<b>Drawing</b>	
		 tungsten carbide [HW]

<b>Machine / Application</b>	<b>Design</b>	<b>Advantages</b>	<b>Notes</b>
edge banding machines Homag, IMA, Reich   for use in scrapper holders	chamfer angle 45 degrees   cutting material: HW   HL Board 05 for wood-based panels, plastics and hard woods		packing unit: 10 pieces

B	H	S	Ø d		Ident-No.
12	20	2	4		171180
[mm]	[mm]	[mm]	[mm]		

15 1555

### Scrapper Turnover Knives HW with 2 cutting edges and radius - Homag, Reich

Product

Drawing

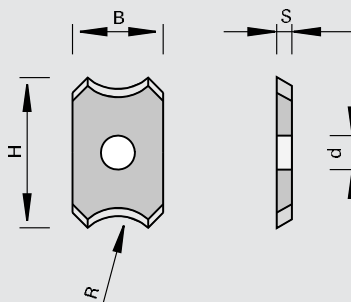

tungsten carbide [HW]

Machine / Application

- edge banding machines Homag, Reich
- for use in scraper holders

Design

- 6 degree profile run-out
- cutting material: HW
- HL Board 05 for wood-based panels, plastics and hard woods

Advantages

Notes

- packing unit: 10 pieces

R	B	H	S	Ø d	Ident-No.
0,8	12	20	2	4	171401 s
1	12	20	2	4	169253
1,5	12	20	2	4	169254
2	12	20	2	4	169255
2,5	12	20	2	4	169256
3	12	20	2	4	169257
4	12	20	2	4	169259
5	12	20	2	4	169261
[mm]	[mm]	[mm]	[mm]	[mm]	

15 1555

### Scrapper Turnover Knives HW with 2 cutting edges and radius - IMA

Product

Drawing

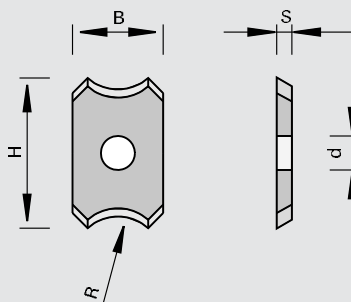

tungsten carbide [HW]

Machine / Application

- edge banding machines IMA
- for use in scraper holders

Design

- 15 degree profile run-out
- cutting material: HW
- HL Board 05 for wood-based panels, plastics and hard woods

Advantages

Notes

- packing unit: 10 pieces

R	B	H	S	Ø d	Ident-No.
1	12	20	2	4	178856
2	12	20	2	4	178957
3	12	20	2	4	178857
[mm]	[mm]	[mm]	[mm]	[mm]	

151755

### Scaper Turnover Knives HW with 2 cutting edges and radius - Homag

<b>Product</b>	<b>Drawing</b>		
			tungsten carbide [HW]

<b>Machine / Application</b>	<b>Design</b>	<b>Advantages</b>	<b>Notes</b>
<ul style="list-style-type: none"> <li>  edge banding machines Homag</li> <li>  for use in scaper holders</li> </ul>	<ul style="list-style-type: none"> <li>  6 degree profile run-out</li> <li>  special scaper which avoids material fracturing</li> <li>  cutting material: HW</li> <li>  HL Board 05 for wood-based panels, plastics and hard woods</li> </ul>	<ul style="list-style-type: none"> <li>  no material fracturing also in the case of PP-edges</li> <li>  no additional work steps needed</li> </ul>	<ul style="list-style-type: none"> <li>  packing unit: 10 pieces</li> </ul>

R	B	H	S	Ø d	Ident-No.
1,5	12	20	2	4	181234
2	12	20	2	4	181235
3	12	20	2	4	181237
[mm]	[mm]	[mm]	[mm]	[mm]	

151755

### Scaper Turnover Knives HW with 2 cutting edges and radius - IMA

<b>Product</b>	<b>Drawing</b>		
			tungsten carbide [HW]

<b>Machine / Application</b>	<b>Design</b>	<b>Advantages</b>	<b>Notes</b>
<ul style="list-style-type: none"> <li>  edge banding machines IMA</li> <li>  for use in scaper holders</li> </ul>	<ul style="list-style-type: none"> <li>  15 degree profile run-out</li> <li>  special scaper which avoids material fracturing</li> <li>  cutting material: HW</li> <li>  HL Board 05 for wood-based panels, plastics and hard woods</li> </ul>	<ul style="list-style-type: none"> <li>  no material fracturing also in the case of PP-edges</li> <li>  no additional work steps needed</li> </ul>	<ul style="list-style-type: none"> <li>  packing unit: 10 pieces</li> </ul>

R	B	H	S	Ø d	Ident-No.
2	12	20	2	4	181236
3	12	20	2	4	181238
[mm]	[mm]	[mm]	[mm]	[mm]	

15 1586

### Scrapper Knives HW with 2 cutting edges and radius - working centers

Product

Drawing

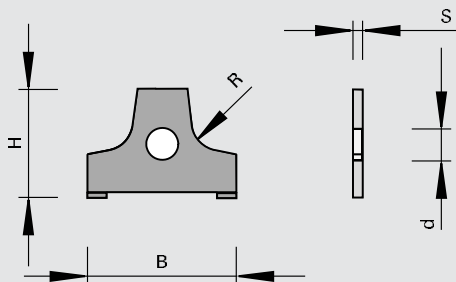

tungsten carbide [HW]

Machine / Application

l machines Homag combined with flush-cutting unit No. 1-056-11-0621

Design

l 6 degree profile run-out  
l cutting material: HW  
l HL Board 06 for wood-based panels, plastics and hard woods

Advantages

Notes

l packing unit: 10 pieces

R	B	H	S	Ø d	Ident-No.
1,5	20	11.5	2	5	180025
2	20	11.5	2	5	180020
2,5	20	11.5	2	5	180021
3	20	11.5	2	5	180022
[mm]	[mm]	[mm]	[mm]	[mm]	

15 1586

### Scrapper Knives HW with 2 cutting edges and chamfer (glue joint) - working centers

Product

Drawing

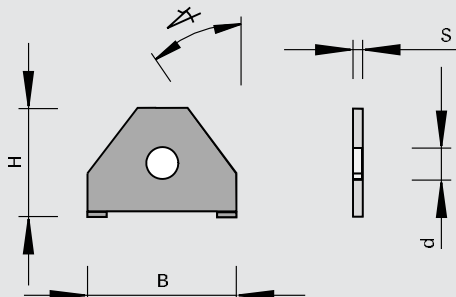

tungsten carbide [HW]

Machine / Application

l machines Homag combined with flush-cutting unit No. 1-056-11-0621

Design

l cutting material: HW  
l HL Board 06 for wood-based panels, plastics and hard woods

Advantages

Notes

l packing unit: 10 pieces

Chamfer $\sphericalangle$	B	H	S	Ø d	Ident-No.
3	20	11.5	2	5	180023
[°]	[mm]	[mm]	[mm]	[mm]	

151586

### Chip Breakers HW for Scraper Knives

Product		Drawing			 tungsten carbide [HW]	
Machine / Application		Design	Advantages		Notes	
machines Homag combined with flush-cutting unit No. 1-056-11-0621		6 degree profile run-out   cutting material: HW   HL Board 06 for wood-based panels, plastics and hard woods			packing unit: 10 pieces	
R	B	H	S	Ø d	Ident-No.	
1,3 [mm]	20 [mm]	11.5 [mm]	2 [mm]	5 [mm]	180024	

151586

### Scraper Knives HW with 5 cutting edge and chamfer

Product		Drawing			 tungsten carbide [HW]	
Machine / Application		Design	Advantages		Notes	
machines Homag with scraping unit Type MN 20		chamfer 20 degrees, R1, R1,5, R2, R3, R5   cutting material: HW   HL Board 06 for wood-based panels, plastics and hard woods			Ident-No. 180755 can be applied on the left lower or the right upper side   Ident-No. 180754 can be applied on the left upper or the right lower side   packing unit: 10 pieces	
R	B	H	S	Ø d	Ident-No. [L]	Ident-No. [R]
1-5 [mm]	45,8 [mm]	17.98 [mm]	2 [mm]	5 [mm]	180755	180754

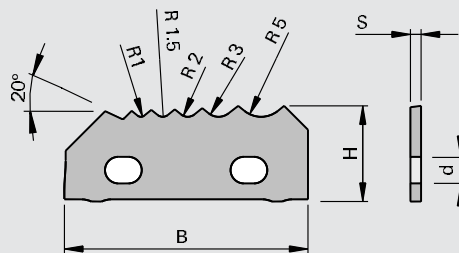



15 1786

### Scrapper Knives HW with 5 cutting edge and chamfer (no material fracturing)

Product

Drawing

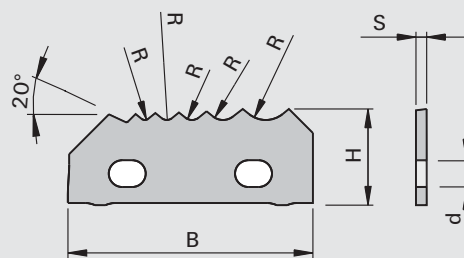

tungsten carbide [HW]

Machine / Application

l machines Homag with scraping unit Type MN 20

Design

l chamfer 20 degree, R1, R1,5, R2, R3, R5 or chamfer 20 degree, R1, R1,5, R2, R2,5, R3  
 l special scrapper which avoids material fracturing  
 l cutting material: HW  
 l HL Board 06 for wood-based panels, plastics and hard woods

Advantages

l no material fracturing also in the case of PP-edges  
 l no additional work steps needed

Notes

l Ident-No. 181239 and 184669 can be applied on the left lower or the right upper side  
 l Ident-No. 181240 and 184670 can be applied on the left upper or the right lower side  
 l packing unit 10 pieces

R	B	H	S	Ø d	Ident-No. [L]	Ident-No. [R]
1; 1,5; 2; 3; 5	45,8	17,98	2	5	181240	181239
1; 1,5; 2; 2,5; 3	45,8	17,02	2	5	184670	184669
[mm]	[mm]	[mm]	[mm]	[mm]		

15 1548

### Scrapper Knives HW with 1 cutting edge and chamfer

Product

Drawing

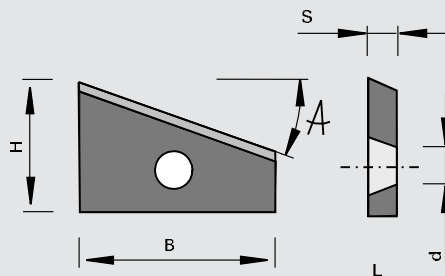

tungsten carbide [HW]

Machine / Application

l machines IMA units 181.91 and 0.6126 (BAZ) with 30 mm width, unit 08.50 with 55 mm width

Design

l cutting material: HW  
 l HL Solid 15 for wood-based panels, hard and soft woods

Advantages

Notes

l packing unit: 2 pieces

Chamfer	B	H	S	Ø d	Ident-No. [L]	Ident-No. [R]
15	30	22,5	3	5,8	178859	178858
15	55	25	3	5,8	178861	178860
[°]	[mm]	[mm]	[mm]	[mm]		

132821

### Scaper Knives HW with 1 cutting edge and chamfer

<b>Product</b>	<b>Drawing</b>	
		tungsten carbide [HW]

<b>Machine / Application</b>	<b>Design</b>	<b>Advantages</b>	<b>Notes</b>
machines Homag	HW-tipped   cutting material: HW   HL Solid 15 for wood-based panels, hard and soft woods		packing unit: 2 pieces

Chamfer $\sphericalangle$	B	H	S	$\varnothing$ d	Ident-No. [L]	Ident-No. [R]
15 [°]	32 [mm]	55 [mm]	4.5 [mm]	5,8 [mm]	178223	178224

132821

### Scaper Turnover Knives HW with 3 cutting edges - Biesse

<b>Product</b>	<b>Drawing</b>	
		tungsten carbide [HW]

<b>Machine / Application</b>	<b>Design</b>	<b>Advantages</b>	<b>Notes</b>
machines Biesse-Polymax	cutting material: HW   HL Solid 30 for wood-based panels, hard and soft woods		packing unit: 10 pieces

B	H	S	$\varnothing$ d	Corner $\sphericalangle$	LEUCODUR	Ident-No.
22,9 [mm]	19.8 [mm]	2.5 [mm]	6,4 [mm]	60 [°]	HL Solid 30	183685 o

150518

## Scrapper Turnover Knives HW with 2 cutting edges - IMA

Product

Drawing

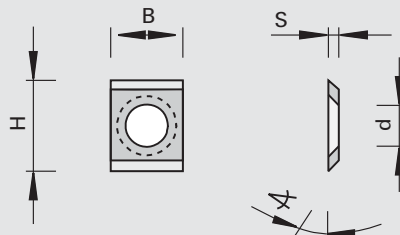

tungsten carbide [HW]

Machine / Application

| machines IMA

Design

| cutting material: HW  
| HL Solid 25 for hard and soft woods

Advantages

Notes

| packing unit: 10 pieces

B	H	S	Ø d	Ident-No.
11 [mm]	14.3 [mm]	2.5 [mm]	4 [mm]	184350

150503

## Cup Knives HW

Product

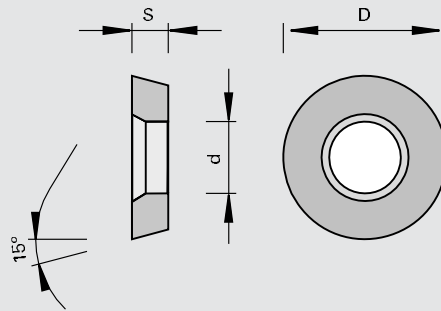

Drawing

LEUCO  
DUR

tungsten carbide [HW]

Machine / Application

- for use in side-and-face cutterheads

Design

- cutting material: HW
- HL Board 03 for wood-based panels and plastics

Advantages

- extremely long edge lives

Notes

- packing unit: 10 pieces

$\varnothing D$	S	$\varnothing d$	Ident-No.
11	4	5	173396
[mm]	[mm]	[mm]	

153306 / 153308

## Saw Teeth HW for Circular Saw Blades - solder coated

Product

Drawing

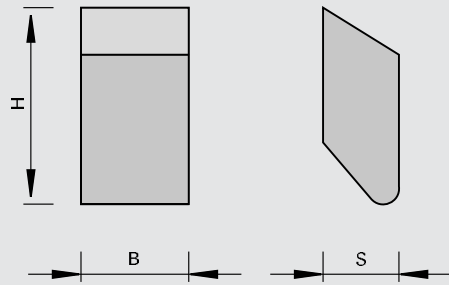

tungsten carbide [HW]

Machine / Application

Design

Advantages

Notes

- | solder-coated
- | cutting material: HW
- | HL Board 06 for wood-based panels, plastics and hard woods
- | HL Solid 15 for wood-based panels, hard and soft woods

- | easy soldering during tooth installation thanks to solder coating

B	H	S	LEUCODUR	Ident-No.
2,7	7.1	2	HL Board 06	177493 s
2,8	8	2.3	HL Solid 15	177500 s
3,6	8	2.3	HL Board 06	177494
4,2	10.5	3.5	HL Solid 15	177501
4,5	8	2.3	HL Board 06	177495
4,3	10.5	3	HL Board 06	177496
5	10.5	3	HL Board 06	177497
5,4	10.5	3	HL Board 06	177498
6	12.5	4	HL Solid 15	177586
6,8	12.5	4	HL Board 06	177499
[mm]	[mm]	[mm]		

332121

## Planing Knives HS

Product



Drawing

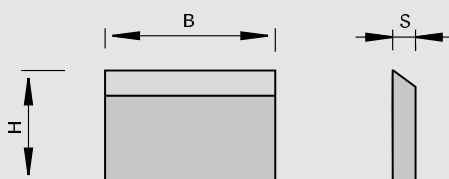

High Speed Steel [HS]

Machine / Application

| for use in planing cutterheads

Design

| cutting material: high speed steel (HS 18%) for soft woods

Advantages

Notes

| from safety reasons please always mount knives and support plates with equal weight (packing unit VE) opposite each other

| packing unit 2 pieces

B	H	S	Ident-No.
60	30	3	160593
80	30	3	160594
100	30	3	055647
110	30	3	160595 o
120	30	3	160596
130	30	3	006139
150	30	3	160597
170	30	3	160598
180	30	3	160599
210	30	3	160600
230	30	3	160601
260	30	3	006485
310	30	3	160602
310	35	3	165310
320	30	3	160603
320	35	3	165311 o
330	30	3	160604 o
330	35	3	165312
360	30	3	160605 o
360	35	3	165313 o
400	30	3	165307
400	35	3	165314 o
410	30	3	006486
410	35	3	006487
450	30	3	160606 o
450	35	3	165315 o
460	30	3	160607 o
460	35	3	165316 o
500	30	3	165308
500	35	3	165317
510	30	3	006488
510	35	3	006489
600	30	3	165309 o
600	35	3	165318 o
610	30	3	006490
610	35	3	006491
630	30	3	160608
630	35	3	165319
635	35	3	165320 o
640	30	3	160609
640	35	3	165321
[mm]	[mm]	[mm]	

B	H	S	Ident-No.
700	35	3	165322 o
710	30	3	160610 o
710	35	3	165323 o
740	35	3	165324 o
810	30	3	160612
810	35	3	165325
840	30	3	160613 o
1050	30	3	176331
1050	35	3	176332
1200	30	3	180535
[mm]	[mm]	[mm]	

332121

Planing knife HS for hydro and jointing

Product



Drawing

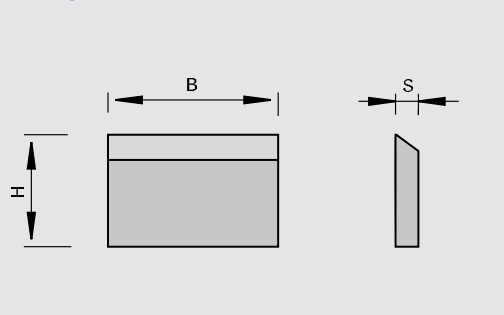

High Speed Steel [HS]
-----------------------

Machine / Application

for use in hydro planing cutterheads

Design

cutting material: HS for soft woods  
wedge angle 30° for jointing

Advantages

high run-out accuracy due to grinding the knives in the hydro planing cutterhead with following jointing process in the machine

Notes

from safety reasons please always mount knives and support plates with equal weight (packing unit VE) opposite each other  
packing unit 2 pieces

B	H	S	Ident-No.
130	30	3	182759 o
150	30	3	182760 o
170	30	3	182761 o
180	30	3	182762 o
190	30	3	182763 o
210	30	3	182764 o
230	30	3	182765 o
240	30	3	182766 o
270	30	3	182767 o
310	30	3	182768 o
[mm]	[mm]	[mm]	

132121

## Planing Knives HW

Product

Drawing

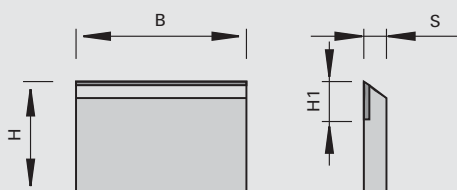
LEUCO  
DUR

tungsten carbide [HW]

Machine / Application

| for use in planing cutterheads

Design

| cutting material: HW-tipped for hard woods

Advantages

Notes

| from safety reasons please always mount knives and support plates with equal weight (packing unit VE) opposite each other

| packing unit 2 pieces

B	H	S	H1	Ident-No.
60	30	3	11	160586
80	30	3	11	006204
100	30	3	11	006205
110	30	3	11	165329 o
120	30	3	11	006206 o
130	30	3	11	006207
150	30	3	11	006208
170	30	3	11	006209
180	30	3	11	055649
210	30	3	11	006210 o
230	30	3	11	160588
240	30	3	11	182641
260	30	3	11	160589 o
310	30	3	11	055648
310	35	3	11	165338 o
320	30	3	11	165330 o
320	35	3	11	165339 o
330	30	3	11	165331 o
330	35	3	11	165340 o
360	30	3	11	165332 o
360	35	3	11	165341 o
400	35	3	11	165342 o
410	30	3	11	006211
410	35	3	11	165343 o
450	30	3	11	165333 o
450	35	3	11	165344 o
460	30	3	11	165334 o
460	35	3	11	165345 o
500	35	3	11	165346 o
510	30	3	11	006212
510	35	3	11	165347 o
600	35	3	11	165348 o
610	30	3	11	006704
610	35	3	11	165349 o
630	30	3	11	165335 o
630	35	3	11	165350 o
635	35	3	11	165351 o
640	30	3	11	165336 o
640	35	3	11	165352 o
700	35	3	11	165353 o
710	30	3	11	160590 o
[mm]	[mm]	[mm]	[mm]	



B	H	S	H1	Ident-No.
710	35	3	11	165354 o
740	30	3	11	165337 o
740	35	3	11	165355 o
810	30	3	11	160592
810	35	3	11	165356 o
[mm]	[mm]	[mm]	[mm]	

332511

Planing Knives with serrated back HS

Product



Drawing

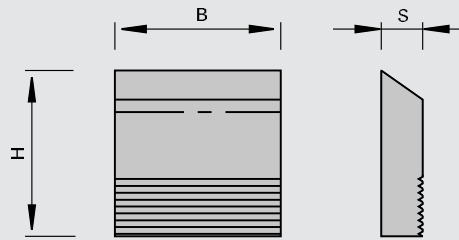

High Speed Steel [HS]

Machine / Application

for use in cutterheads with serration

Design

cutting material: HS for soft woods

Advantages

Notes

- from safety reasons please always mount knives and support plates with equal weight (packing unit VE) opposite each other
- also for Weinig Powermat machines, RPM up to 12,000 min-1
- packing unit 2 pieces

B	H	S	Ident-No.
100	38	5	182096 s
130	38	5	182097 s
170	38	5	182098 s
190	38	5	182099 s
230	38	5	182100 s
240	38	5	182101 s
[mm]	[mm]	[mm]	

332511

## Planing Knives with serrated back HS - Quicklock

Product



Drawing

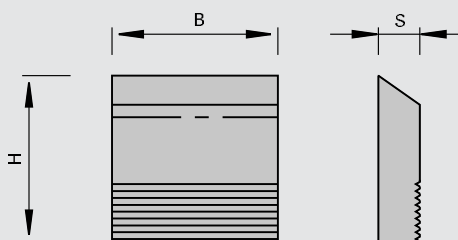

High Speed Steel [HS]

## Machine / Application

for use in hydro planing  
cutterheads Quicklock with  
serration

## Design

cutting material: HS for soft  
woods

## Advantages

## Notes

from safety reasons please  
always mount knives and  
support plates with equal  
weight (packing unit VE)  
opposite each other  
packing unit 2 pieces

B	H	S	Ident-No.
100	30	4	183354 o
130	30	4	183355 o
150	30	4	183356 o
180	30	4	183357 o
210	30	4	183358 o
230	30	4	183359 o
240	30	4	183360 o
270	30	4	183361 o
310	30	4	183362 o
320	30	4	183363 o
100	35	4	183364 o
130	35	4	183365 o
150	35	4	183366 o
180	35	4	183367 o
210	35	4	183368 o
230	35	4	183369 o
240	35	4	183370 o
270	35	4	183371 o
310	35	4	183372 o
320	35	4	183373 o
[mm]	[mm]	[mm]	

152548

## SetProfiler set - planing

Product

Drawing

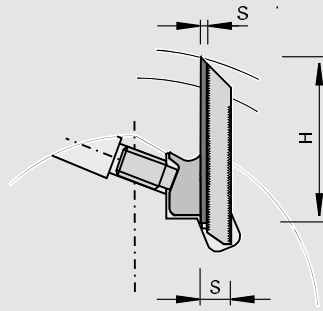

tungsten carbide [HW]

Machine / Application

- | molders
- | for use in profile cutterheads with serration

Design

- | n max = 12,000 min-1
- | cutting material: HW
- | HL Solid 30 Topline for hard and soft woods
- | HW Topcoat
- | Topline (polished face)

Advantages

- | significantly improved cutting edges
- | excellent cutting quality
- | compared to uncoated HW-Blanks the edge lives is 2 - 3 times as long
- | adjustable knives by means of serration between knife and support plate; 5 adjustments of 1,6 mm = 8 mm sharpening area

Notes

- | from safety reasons please always mount knives and support plates with equal weight (packing unit VE) opposite each other
- | packing unit 2 pieces

B	H	S	Ident-No.
310	38	10	181974 o
[mm]	[mm]	[mm]	

Blanks	B	H	S	Class-No.	Ident-No.
HW Blanks	310	38	3.2	152548	181975 o
HW Topcoat Blanks	250	38	3.2	152548	181976 o
	[mm]	[mm]	[mm]		

Support plates	B	Suitable for blank height	Class-No.	Ident-No.
	250	38	925400	181977 o
	310	38	925400	181978 o
	[mm]	[mm]		

152548

## SetProfiler set - profiling

Product

Drawing

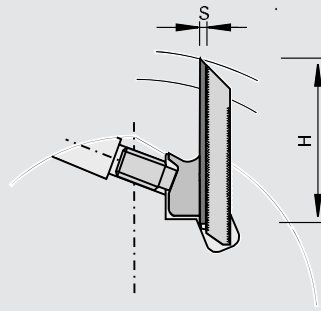
LEUCO  
toplineLEUCO  
DUR

tungsten carbide [HW]

## Machine / Application

- | molders
- | for use in profile cutterheads with serration

## Design

- | cutting material: HW
- | HL Solid 30 for hard and soft woods
- | HW Topcoat
- | Topline (polished face)

## Advantages

- | significantly improved cutting edges
- | excellent cutting quality
- | compared to uncoated HW-Blanks the edge lives is 2 - 3 times as long
- | high economic efficiency thanks to reduced use of grinding wheels, as knives and support plates are profiled separately whereas only the knives are re-ground
- | adjustable knives by means of serration between knife and support plate; 5 adjustments of 1,6 mm = 8 mm sharpening area

## Notes

- | serration 60 degrees and partition 1,6 mm for profiling of solid woods and wood-based panels
- | blank height 50 and 60 mm for RPM up to 12,000 min-2
- | T = profile depth
- | from safety reasons please always mount knives and support plates with equal weight (packing unit VE) opposite each other
- | packing unit 2 pieces

B	H	S	Tmax	Ident-No.
40	50	10	14	181637 o
50	50	10	14	181638 o
60	50	10	14	181639 o
70	50	10	14	181640 o
80	50	10	14	181641 o
100	50	10	14	182182 o
130	50	10	14	182183 o
150	50	10	14	182184 o
250	50	10	14	181642 o
40	60	10	24	181643 o
50	60	10	24	181644 o
60	60	10	24	181645 o
70	60	10	24	181646 o
80	60	10	24	181647 o
100	60	10	24	182322 o
130	60	10	24	182323 o
150	60	10	24	182324 o
250	60	10	24	181648 o
40	70	10	34	181649 o
50	70	10	34	181650 o
60	70	10	34	181651 o
70	70	10	34	181652 o
80	70	10	34	181653 o
250	70	10	34	181654 o
[mm]	[mm]	[mm]	[mm]	

HW Blanks Topline	B	H	S	T	Class-No.	Ident-No.
	40	50	3.2	14	152548	181619
	50	50	3.2	14	152548	181620 o
	60	50	3.2	14	152548	181621
	70	50	3.2	14	152548	181622 o
	80	50	3.2	14	152548	181623 o
	100	50	3.2	14	152548	182179
	130	50	3.2	14	152548	182180
	150	50	3.2	14	152548	182181 o
	250	50	3.2	14	152548	181624
	40	60	3.2	24	152548	181625
	50	60	3.2	24	152548	181626 o
	60	60	3.2	24	152548	181627
	70	60	3.2	24	152548	181628 o
	80	60	3.2	24	152548	181629
	100	60	3.2	24	152548	182319
	130	60	3.2	24	152548	182320 o
	150	60	3.2	24	152548	182321 o
	250	60	3.2	24	152548	181630
	40	70	3.2	34	152548	181631 o
	50	70	3.2	34	152548	181632 o
	60	70	3.2	34	152548	181633 o
	70	70	3.2	34	152548	181634 o
	80	70	3.2	34	152548	181635 o
	250	70	3.2	34	152548	181636
	[mm]	[mm]	[mm]	[mm]		
HW Topcoat Blanks	B	H	S	T	Class-No.	Ident-No.
	40	50	3.2	14	152548	181665 o
	50	50	3.2	14	152548	181666 o
	60	50	3.2	14	152548	181667 o
	70	50	3.2	14	152548	181668 o
	80	50	3.2	14	152548	181669 o
	100	50	3.2	14	152548	182188 o
	130	50	3.2	14	152548	182189 o
	150	50	3.2	14	152548	182190 o
	250	50	3.2	14	152548	181670 o
	40	60	3.2	24	152548	181671 o
	50	60	3.2	24	152548	181672 o
	60	60	3.2	24	152548	181673 o
	70	60	3.2	24	152548	181674 o
	80	60	3.2	24	152548	181675 o
	100	60	3.2	24	152548	182328 o
	130	60	3.2	24	152548	182329 o
	150	60	3.2	24	152548	182330 o
	250	60	3.2	24	152548	181676 o
	[mm]	[mm]	[mm]	[mm]		

Support plates	B	Suitable for blank height	Class-No.	Ident-No.
	40	50	925400	181820
	50	50	925400	181821 o
	60	50	925400	181822
	70	50	925400	181823
	80	50	925400	181824
	100	50	925400	182185
	130	50	925400	182186
	150	50	925400	182187 o
	250	50	925400	181825 o
	40	60	925400	181826
	50	60	925400	181827
	60	60	925400	181828
	70	60	925400	181829
	80	60	925400	181830
	100	60	925400	182325
	130	60	925400	182326 o
	150	60	925400	182327 o
	250	60	925400	181831 o
	40	70	925400	181832 o
	50	70	925400	181833 o
	60	70	925400	181834 o
	70	70	925400	181835 o
	80	70	925400	181836 o
	250	70	925400	181837 o
	[mm]	[mm]		



332511

## Blanks with serrated back HS for profiling

Product



Drawing

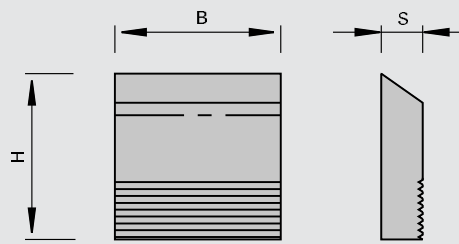

High Speed Steel [HS]

Machine / Application

for use in profile cutterheads with serration

Design

cutting material: HS for soft woods

Advantages

Notes

T = profile depth  
 from safety reasons please always mount knives and support plates with equal weight (packing unit VE) opposite each other  
 packing unit 2 pieces

B	H	S	Tmax	Ident-No.
40	50	8	12	163385
40	60	8	20	163386
40	70	8	30	163387
50	50	8	12	180533
50	60	8	20	180534
60	50	8	12	163388
60	60	8	20	163389
60	70	8	30	163390
80	50	8	12	163391
80	60	8	20	163392
80	70	8	30	163393
100	50	8	12	163394
100	60	8	20	163395
100	70	8	30	163396
130	50	8	12	163397
130	60	8	20	163398
130	70	8	30	163399
150	50	8	12	163400
150	60	8	20	163401
150	70	8	30	163402
180	50	8	12	163403
180	60	8	20	163404
180	70	8	30	163405
230	50	8	12	164495
230	60	8	20	164496 o
650	50	8	12	176318
650	60	8	20	176319
650	70	8	30	176320
[mm]	[mm]	[mm]	[mm]	

132511

## Blanks with serrated back HW for profiling

Product

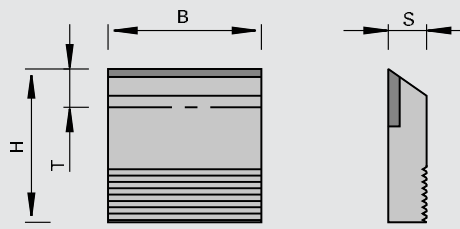

Drawing

LEUCO  
DUR

tungsten carbide [HW]

## Machine / Application

for use in profile cutterheads with serration

## Design

HW-tipped for hard and exotic woods  
tipping height 14 mm for blank height 50 mm, tipping height 20 mm for blank height 60 mm

## Advantages

## Notes

T = profile depth  
from safety reasons please always mount knives and support plates with equal weight (packing unit VE) opposite each other  
packing unit 2 pieces

B	H	S	Tmax	Ident-No.
40	50	10	13	165357
40	60	10	18	165365
60	50	10	13	165358
60	60	10	18	165366
80	50	10	13	165359 o
80	60	10	18	165367
100	50	10	13	165360
100	60	10	18	165368
130	50	10	13	165361 o
130	60	10	18	165369
150	50	10	13	165362 o
150	60	10	18	165370 o
180	50	10	13	165363 o
180	60	10	18	165371 o
230	50	10	13	165364 o
230	60	10	18	165372 o
[mm]	[mm]	[mm]	[mm]	



332521

## Blanks HS and Deflector Blanks for profiling

Product



Drawing

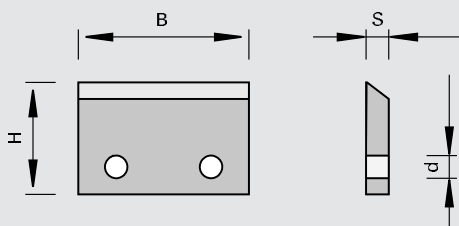

High Speed Steel [HS]

Machine / Application

| for use in safety cutterheads

Design

| cutting material: HS for soft woods  
| profile depth 15 mm max.

Advantages

Notes

| special steel deflector blanks

B	H	S	Ø d	Tmax	Ident-No.
40	45	4	6	15	163535
50	45	4	6	15	163513 o
[mm]	[mm]	[mm]	[mm]	[mm]	

Deflectors for profiling

B	H	S	Ø d	T	Class-No.	Ident-No.
40	45	4	6	15	925400	163536
50	45	4	6	15	925400	163514 o
[mm]	[mm]	[mm]	[mm]	[mm]		

152555

## Blanks HW

Product

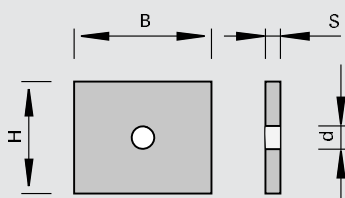

Drawing

LEUCO  
DUR

tungsten carbide [HW]

Machine / Application

| for use in profile cutterheads

Design

| width, height, and thickness  
| precision ground  
| cutting material: HW  
| HL Board 05 for wood-based panels, plastics and hard woods

Advantages

Notes

| packing unit: 10 pieces

B	H	S	Ø d	L	Ident-No.
24	22	2	4,5		168821
28	24	2	4,2		168822 #
32	24	2	4,5		168823
36	28	2	4,2		168824
40	26	2	4,5		168825 #
42	32	2	4,5	24	168826
52	34	2	4,2	24	168828
[mm]	[mm]	[mm]	[mm]	[mm]	

152555

## Blanks HW

Product

Drawing

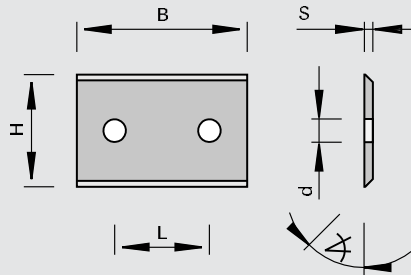
LEUCO  
DUR

tungsten carbide [HW]

Machine / Application

| for use in profile cutterheads

Design

| width, height, and thickness  
precision ground  
| cutting material: HW  
| HL Board 05 for wood-based  
panels, plastics and hard  
woods

Advantages

Notes

| packing unit: 10 pieces

B	H	S	Ø d	L	Wedge	Ident-No.
30	25	2	4,2	20	55	168871 #
40	30	2	4,2	20	55	168872
50	45	2	4,2	34	55	168873
60	25	2	4,2	26	55	168836
[mm]	[mm]	[mm]	[mm]	[mm]	[°]	

152545

## Blanks HW

Product

Drawing

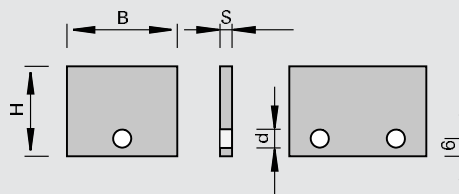
LEUCO  
DUR

tungsten carbide [HW]

Machine / Application

| for use in profile cutterheads

Design

| width, height, and thickness  
precision ground  
| cutting material: HW  
| HL Board 05 for wood-based  
panels, plastics and hard  
woods

Advantages

Notes

| packing unit: 10 pieces

B	H	S	Ø d	L	Ident-No.
18	18.3	2	4,5		168829
20	25.3	2	4,2		168830
24	28.3	2	4,5		168831
32	22.3	2	4,5		168832
40	30.3	2	4,5		168833
50	32.3	2	4,5	24	168834
[mm]	[mm]	[mm]	[mm]	[mm]	

152545

## Blanks HW

Product

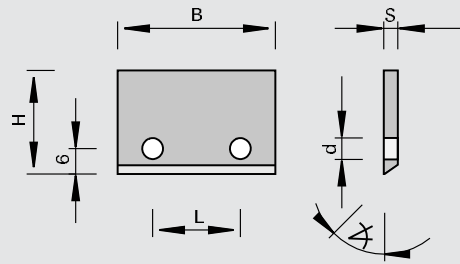

Drawing

LEUCO  
DUR

tungsten carbide [HW]

Machine / Application

| for use in profile cutterheads

Design

| width, height, and thickness  
 precision ground  
 | cutting material: HW  
 | HL Board 05 for wood-based  
 panels, plastics and hard  
 woods

Advantages

Notes

| packing unit: 10 pieces

B	H	S	Ø d	L	Wedge∠	Ident-No.
40	20.5	2	4,2	26	55	168838
52	27.5	2	4,2	26	55	168839
60	39.5	2	4,2	44	55	168840
[mm]	[mm]	[mm]	[mm]	[mm]	[°]	

152586 / 152589

**3P blanks HW**

Product

Drawing

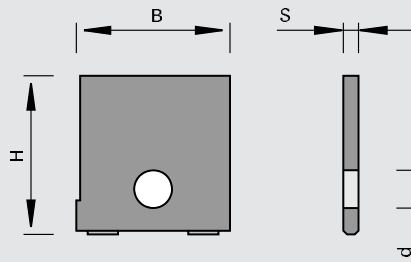
LEUCO  
DUR

tungsten carbide [HW]

Machine / Application

- for use in LEUCO EcoPro and special cutterheads

Design

- two-point seating surface and point-stop
- cutting material: HW
- HL Board 06 for wood-based panels, plastics and hard woods
- HL Solid 60 for soft woods

Advantages

- precise positioning of the blanks for profiling and of the single-sided profile knife in the cutterhead

Notes

- profile knife can be profiled per customer specifications
- packing unit: 10 pieces

B	H	S	Ø d	LEUCODUR	Ident-No.
12,5	20.5	2	5	HL Board 06	178509
15,5	20.5	2	5	HL Board 06	178510
15,5	25.5	2	5	HL Board 06	178511
16,4	20.5	2	5	HL Board 06	178512
16,7	25.9	2	5	HL Board 06	178513
18,4	18.9	2	5	HL Board 06	178514
18,4	25.9	2	5	HL Board 06	178515
18,4	36.3	2	5	HL Board 06	178516
20,3	20.5	2	5	HL Board 06	178517
20,3	25.5	2	5	HL Board 06	178518
20,3	30.4	2	5	HL Board 06	178519
22,3	25.5	2	5	HL Board 06	178520
24,3	20.9	2	5	HL Board 06	178521
24,3	28.4	2	5	HL Board 06	178522
25,3	25.9	2	5	HL Board 06	178523
25,3	35.3	2	5	HL Board 06	178524
28,2	25.5	2	5	HL Board 06	178525
28,2	35.3	2	5	HL Board 06	178526
12,5	20.5	2	5	HL Solid 60	179509
15,5	20.5	2	5	HL Solid 60	179510
15,5	25.5	2	5	HL Solid 60	179511
16,4	20.5	2	5	HL Solid 60	179512
16,7	25.9	2	5	HL Solid 60	179513
18,4	18.9	2	5	HL Solid 60	179514
18,4	25.9	2	5	HL Solid 60	179515
18,4	36.3	2	5	HL Solid 60	179516
20,3	20.5	2	5	HL Solid 60	179517
20,3	25.5	2	5	HL Solid 60	179518
20,3	30.4	2	5	HL Solid 60	179519
22,3	25.5	2	5	HL Solid 60	179520
24,3	20.9	2	5	HL Solid 60	179521 #
24,3	28.4	2	5	HL Solid 60	179522
25,3	25.9	2	5	HL Solid 60	179523
25,3	35.3	2	5	HL Solid 60	179524
28,2	25.5	2	5	HL Solid 60	179525
28,2	35.3	2	5	HL Solid 60	179526
[mm]	[mm]	[mm]	[mm]		

152586 / 152589

## 3P blanks HW

Product

Drawing

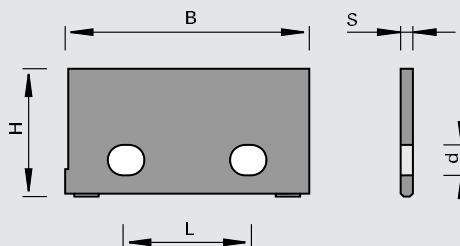
LEUCO  
DUR

tungsten carbide [HW]

Machine / Application

for use in LEUCO EcoPro and special cutterheads

Design

two-point seating surface and point-stop  
cutting material: HW  
HL Board 06 for wood-based panels, plastics and hard woods  
HL Solid 60 for soft woods

Advantages

precise positioning of the blanks for profiling and of the single-sided profile knife in the cutterhead

Notes

profile knife can be profiled per customer specifications  
packing unit: 10 pieces

B	H	S	Ø d	L	LEUCODUR	Ident-No.
30,2	25.5	2	5	11,8 - 13,8	HL Board 06	178527
30,2	30.4	2	5	11,8 - 13,8	HL Board 06	178528
32,2	22.8	2	5	11,8 - 13,8	HL Board 06	178529
32,2	35.4	2	5	11,8 - 13,8	HL Board 06	178530
32,8	47.2	2	5	11,8 - 13,8	HL Board 06	178531
35,2	26	2	5	11,8 - 13,8	HL Board 06	178532
40,1	20.9	2	5	21,7 - 25,5	HL Board 06	178533
40,1	30.4	2	5	21,7 - 25,5	HL Board 06	178534
40,8	36	2	5	21,7 - 25,5	HL Board 06	178535
42,8	31	2	5	21,7 - 25,5	HL Board 06	178536
42,8	36	2	5	21,7 - 25,5	HL Board 06	178537
45,8	36	2	5	21,7 - 25,5	HL Board 06	178538
49,9	20.9	2	5	21,7 - 25,5	HL Board 06	178539
49,9	33	2	5	21,7 - 25,5	HL Board 06	178540
49,9	40.2	2	5	21,7 - 25,5	HL Board 06	178541
60,6	25.8	2	5	26 - 22	HL Board 06	178542
59,8	35.4	2	5	25,5 + 43,2	HL Board 06	178543
80,6	35.8	2	5	44	HL Board 06	178544
30,2	25.5	2	5	11,8 - 13,8	HL Solid 60	179527
30,2	30.4	2	5	11,8 - 13,8	HL Solid 60	179528
32,2	22.8	2	5	11,8 - 13,8	HL Solid 60	179529
32,2	35.4	2	5	11,8 - 13,8	HL Solid 60	179530
32,8	47.2	2	5	11,8 - 13,8	HL Solid 60	179531
35,2	26	2	5	11,8 - 13,8	HL Solid 60	179532
40,1	20.9	2	5	21,7 - 25,5	HL Solid 60	179533
40,1	30.4	2	5	21,7 - 25,5	HL Solid 60	179534
40,8	36	2	5	21,7 - 25,5	HL Solid 60	179535
42,8	31	2	5	21,7 - 25,5	HL Solid 60	179536
42,8	36	2	5	21,7 - 25,5	HL Solid 60	179537
45,8	36	2	5	21,7 - 25,5	HL Solid 60	179538
49,9	20.9	2	5	21,7 - 25,5	HL Solid 60	179539
49,9	33	2	5	21,7 - 25,5	HL Solid 60	179540
49,2	40.2	2	5	21,7 - 25,5	HL Solid 60	179541
60,6	25.8	2	5	26 - 22	HL Solid 60	179542
59,8	35.4	2	5	25,5 + 43,2	HL Solid 60	179543
80,6	35.8	2	5	44	HL Solid 60	179544 #
[mm]	[mm]	[mm]	[mm]	[mm]		

152786

## 3P blanks HW

Product

Drawing

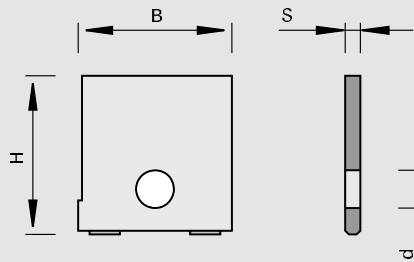
LEUCO  
toplineLEUCO  
DUR

tungsten carbide [HW]

Machine / Application

for use in LEUCO EcoPro and special cutterheads

Design

two-point seating surface and point-stop  
cutting material: HW  
HL Board 06 for wood-based panels, plastics and hard woods  
Topline (polished face)

Advantages

significantly improved cutting edges  
excellent cutting quality  
precise positioning of the blanks for profiling and of the single-sided profile knife in the cutterhead

Notes

figure shows left hand design, top view, polished  
profile knife can be profiled per customer specifications  
packing unit: 10 pieces

B	H	S	Ø d	Ident-No. [L]	Ident-No. [R]
12,5	20.5	2	5	179547 &	179548
15,5	20.5	2	5	179549 &	179550 &
15,5	25.5	2	5	179551 &	179552 &
16,4	20.5	2	5	179553 &	179554 &
16,7	25.9	2	5	179555 &	179556 &
18,4	18.9	2	5	179557 &	179558 &
18,4	25.9	2	5	179559 &	179560 &
18,4	36.3	2	5	179561 &	179562 &
20,3	20.5	2	5	179563 &	179564 &
20,3	25.5	2	5	179565 &	179566 &
20,3	30.4	2	5	179567 &	179568 &
22,3	25.5	2	5	179569 &	179570 &
24,3	20.9	2	5	179571 &	179572 &
24,3	28.4	2	5	179573 &	179574 &
25,3	25.9	2	5	179575	179576
25,3	35.3	2	5	179577 &	179578 &
28,2	25.5	2	5	179579	179580
28,2	35.3	2	5	179581 &	179582 &
[mm]	[mm]	[mm]	[mm]		

152789

## 3P blanks HW

Product

Drawing

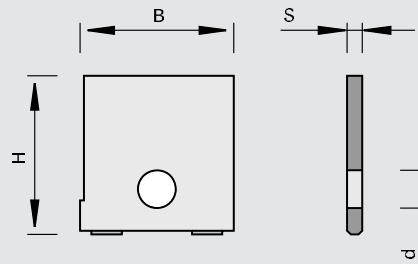
LEUCO  
toplineLEUCO  
DUR

tungsten carbide [HW]

## Machine / Application

- for use in LEUCO EcoPro and special cutterheads

## Design

- two-point seating surface and point-stop
- cutting material: HW
- HL Solid 60 for soft woods
- Topline (polished face)

## Advantages

- significantly improved cutting edges
- excellent cutting quality
- precise positioning of the blanks for profiling and of the single-sided profile knife in the cutterhead

## Notes

- figure shows left hand design, top view, polished
- profile knife can be profiled per customer specifications
- packing unit: 10 pieces

B	H	S	Ø d	Ident-No. [L]	Ident-No. [R]
12,5	20.5	2	5	179621 &	179622 &
15,5	20.5	2	5	179623 &	179624 &
15,5	25.5	2	5	179625 &	179626 &
16,4	20.5	2	5	179627 &	179628 &
16,7	25.9	2	5	179629 &	179630 &
18,4	18.9	2	5	179631 &	179632 &
18,4	25.9	2	5	179633 &	179634 &
18,4	36.3	2	5	179635 &	179636 &
20,3	20.5	2	5	179637 &	179638 &
20,3	25.5	2	5	179639 &	179640 &
20,3	30.4	2	5	179641 &	179642 &
22,3	25.5	2	5	179643 &	179644 &
24,3	20.9	2	5	179645 &	179646 &
24,3	28.4	2	5	179647 &	179648 &
25,3	25.9	2	5	179649 &	179650 &
25,3	35.3	2	5	179651 &	179652 &
28,2	25.5	2	5	179653 &	179654 &
28,2	35.3	2	5	179655 &	179656 &
[mm]	[mm]	[mm]	[mm]		

152786

## 3P blanks HW

Product

Drawing

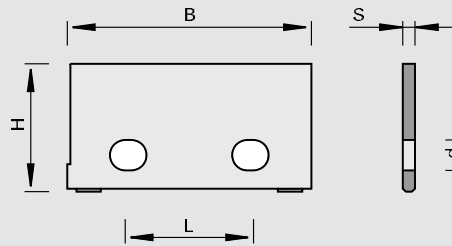
LEUCO  
toplineLEUCO  
DUR

tungsten carbide [HW]

## Machine / Application

for use in LEUCO EcoPro and special cutterheads

## Design

two-point seating surface and point-stop  
cutting material: HW  
HL Board O6 for wood-based panels, plastics and hard woods  
Topline (polished face)

## Advantages

significantly improved cutting edges  
excellent cutting quality  
precise positioning of the blanks for profiling and of the single-sided profile knife in the cutterhead

## Notes

figure shows left hand design, top view, polished  
profile knife can be profiled per customer specifications  
packing unit: 10 pieces

B	H	S	Ø d	L	Ident-No. [L]	Ident-No. [R]
30,2	25.5	2	5	11,8 - 13,8	179583 &	179584 &
30,2	30.4	2	5	11,8 - 13,8	179585 &	179586 &
32,2	22.8	2	5	11,8 - 13,8	179587 &	179588 &
32,2	35.4	2	5	11,8 - 13,8	179589 &	179590 &
32,8	47.2	2	5	11,8 - 13,8	179591 &	179592 &
35,2	26	2	5	11,8 - 13,8	179593	179594
40,1	20.9	2	5	21,7 - 25,5	179595 &	179596 &
40,1	30.4	2	5	21,7 - 25,5	179597 &	179598 &
40,8	36	2	5	21,7 - 25,5	179599 &	179600 &
42,8	31	2	5	21,7 - 25,5	179601 &	179602 &
42,8	36	2	5	21,7 - 25,5	179603 &	179604 &
45,8	36	2	5	21,7 - 25,5	179605 &	179606 &
49,9	20.9	2	5	21,7 - 25,5	179607 &	179608 &
49,9	33	2	5	21,7 - 25,5	179609 &	179610 &
49,9	40.2	2	5	21,7 - 25,5	179611 &	179612 &
60,6	25.8	2	5	22 - 26	179613 &	179614 &
59,8	35.4	2	5	25,5 + 43,2	179615 &	179616 &
80,6	35.8	2	5	44	179617 &	179618 &
[mm]	[mm]	[mm]	[mm]	[mm]		



152789

## 3P blanks HW

Product

Drawing

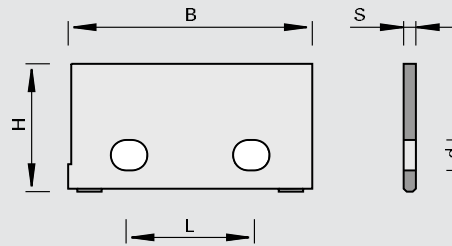
LEUCO  
topline<sub>AS</sub>LEUCO  
DUR

tungsten carbide [HW]

## Machine / Application

- for use in LEUCO EcoPro and special cutterheads

## Design

- two-point seating surface and point-stop
- cutting material: HW
- HL Solid 60 for soft woods
- Topline (polished face)

## Advantages

- significantly improved cutting edges
- excellent cutting quality
- precise positioning of the blanks for profiling and of the single-sided profile knife in the cutterhead

## Notes

- figure shows left hand design, top view, polished
- profile knife can be profiled per customer specifications
- packing unit: 10 pieces

B	H	S	Ø d	L	Ident-No. [L]	Ident-No. [R]
30,2	25.5	2	5	11,8 - 13,8	179657 &	179658 &
30,2	30.4	2	5	11,8 - 13,8	179659 &	179660 &
32,2	22.8	2	5	11,8 - 13,8	179661 &	179662 &
32,2	35.4	2	5	11,8 - 13,8	179663	179664 &
32,8	47.2	2	5	11,8 - 13,8	179665 &	179666 &
35,2	26	2	5	11,8 - 13,8	179667	179668
40,1	20.9	2	5	21,7 - 25,5	179669 &	179670 &
40,1	30.4	2	5	21,7 - 25,5	179671 &	179672 &
40,8	36	2	5	21,7 - 25,5	179673 &	179674 &
42,8	31	2	5	21,7 - 25,5	179675	179676 &
42,8	36	2	5	21,7 - 25,5	179677 &	179678 &
45,8	36	2	5	21,7 - 25,5	179679 &	179680 &
49,9	20.9	2	5	21,7 - 25,5	179681 &	179682 &
49,9	33	2	5	21,7 - 25,5	179683 &	179684 &
49,9	40.2	2	5	21,7 - 25,5	179685 &	179686 &
60,6	25.8	2	5	22 - 26	179687 &	179688 &
59,8	35.4	2	5	25,5 + 43,2	179689 &	179690 &
80,6	35.8	2	5	44	179691 &	179692 &
[mm]	[mm]	[mm]	[mm]	[mm]		

152526 / 152529

## SuperProfiler Blanks HW

Product

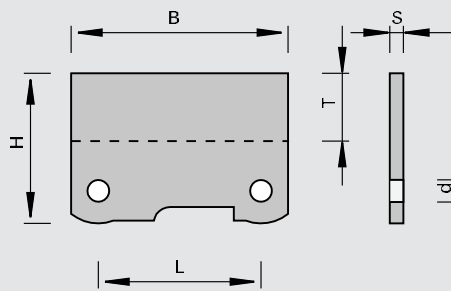

Drawing

LEUCO  
DUR

tungsten carbide [HW]

## Machine / Application

for use in LEUCO SuperProfiler  
cutterheads

## Design

thickness ground  
cutting material: HW  
HL Board 06 for wood-based  
panels, plastics and hard  
woods  
HL Solid 60 for soft woods

## Advantages

## Notes

for concave and convex  
profiles  
T = maximum profile depth

B	H	S	Ø d	L	Tmax	LEUCODUR	Ident-No.
30,6	25.5	1.5	4	16 - 20	13	HL Board 06	179114
30,6	25.5	1.5	4	16 - 20	13	HL Solid 60	177369
40,6	28.2	1.5	4	28	13	HL Board 06	179112
40,6	28.2	1.5	4	28	13	HL Solid 60	177367
40,6	40.6	2	5	28	20	HL Board 06	179115
40,6	40.6	2	5	28	20	HL Solid 60	178844
49,3	33.7	1.5	4	35	16	HL Board 06	180199
60,8	30.2	1.5	4	48	15	HL Board 06	179113
60,8	30.2	1.5	4	48	15	HL Solid 60	177368
60,6	45.6	2	5	45	25	HL Board 06	179999
60,6	45.6	2	5	45	25	HL Solid 60	178845
80,6	45.6	2	6	65	25	HL Board 06	180016
80,6	45.6	2	6	65	25	HL Solid 60	180017
[mm]	[mm]	[mm]	[mm]	[mm]	[mm]		

152726 / 152729

## SuperProfiler Blanks HW

Product

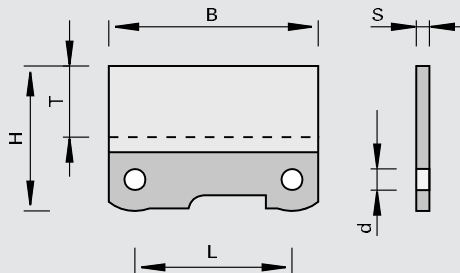

Drawing

LEUCO  
toplineLEUCO  
DUR

tungsten carbide [HW]

Machine / Application

for use in LEUCO SuperProfiler cutterheads

Design

Topline (polished face)  
cutting material: HW  
HL Board 06 for wood-based panels, plastics and hard woods  
HL Solid 60 for soft woods

Advantages

significantly improved cutting edges  
optimum quality of cut

Notes

T = maximum profile depth

B	H	S	Ø d	L	Tmax	LEUCODUR	Ident-No. [L]	Ident-No. [R]
30,6	25,5	1,5	4	16 - 20	13	HL Board 06	178701	178702
30,6	25,5	1,5	4	16 - 20	13	HL Solid 60	177789	177790
40,6	28,2	1,5	4	28	13	HL Board 06	178627	178626
40,6	28,2	1,5	4	28	13	HL Solid 60	177791	177808
40,6	40,6	2	5	28	20	HL Board 06	180030 &	180031
40,6	40,6	2	5	28	20	HL Solid 60	180032 &	180033
49,3	33,7	1,5	4	35	16	HL Board 06	180208	180209
60,8	30,2	1,5	4	48	15	HL Board 06	178643	178628
60,8	30,2	1,5	4	48	15	HL Solid 60	177809	177810
60,6	45,6	2	5	45	25	HL Board 06	180034	180035
60,6	45,6	2	5	45	25	HL Solid 60	180040 &	180041
80,6	45,6	2	6	65	25	HL Board 06	180042	180043
80,6	45,6	2	6	65	25	HL Solid 60	180044	180045
[mm]	[mm]	[mm]	[mm]	[mm]	[mm]			

152726

## SuperProfiler Blanks HW

Product

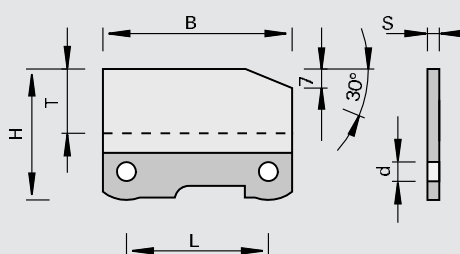

Drawing

LEUCO  
toplineLEUCO  
DUR

tungsten carbide [HW]

Machine / Application

for use in LEUCO SuperProfiler cutterheads

Design

Topline (polished face)  
cutting material: HW  
HL Board 06 for wood-based panels, plastics and hard woods

Advantages

significantly improved cutting edges  
optimum quality of cut

Notes

T = maximum profile depth  
figure shows right hand design, top view, polished

B	H	S	Ø d	L	Tmax	Ident-No. [L]	Ident-No. [R]
49,4	44,5	2	5	35	22	180219	180220
[mm]	[mm]	[mm]	[mm]	[mm]	[mm]		

152526

## SuperProfiler Blanks HW

Product

Drawing

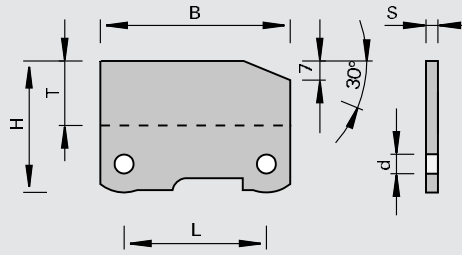
LEUCO  
DUR

tungsten carbide [HW]

Machine / Application

- for use in LEUCO SuperProfiler cutterheads

Design

- cutting material: HW
- HL Board 06 for wood-based panels, plastics and hard woods

Advantages

Notes

- T = maximum profile depth

B	H	S	Ø d	L	Tmax	Ident-No.
49,4	44.5	2	5	35	22	180218
[mm]	[mm]	[mm]	[mm]	[mm]	[mm]	

152536

## PolyProfiler / EcoPro Blanks HW

Product

Drawing

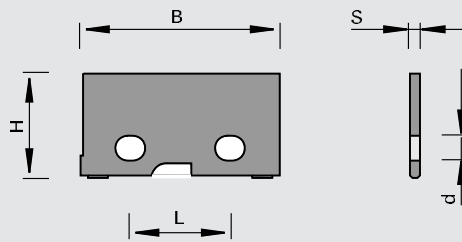
LEUCO  
DUR

tungsten carbide [HW]

Machine / Application

- for use in LEUCO PolyProfiler and EcoPro cutterheads

Design

- two-point seating surface and center stop for axial positioning
- cutting material: HW
- HL Board 06 for wood-based panels, plastics and hard woods

Advantages

- precise positioning of the blanks for profiling and of the single-sided profile knife in the cutterhead

Notes

- profile knife can be profiled per customer specifications
- packing unit: 10 pieces

B	H	S	Ø d	L	Ident-No.
41	32.5	2	5	21,7-25,5	180197
[mm]	[mm]	[mm]	[mm]	[mm]	

152536

## PolyProfiler / EcoPro Blanks HW

Product

Drawing

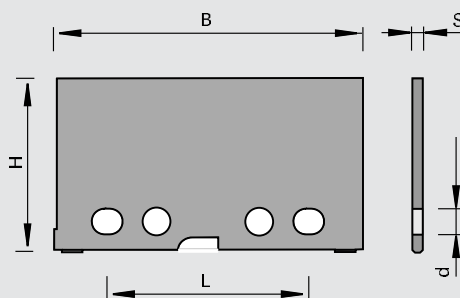
LEUCO  
DUR

tungsten carbide [HW]

Machine / Application

for use in LEUCO PolyProfiler and EcoPro cutterheads

Design

two-point seating surface and center stop for axial positioning  
cutting material: HW  
HL Board 06 for wood-based panels, plastics and hard woods

Advantages

precise positioning of the blanks for profiling and of the single-sided profile knife in the cutterhead

Notes

profile knife can be profiled per customer specifications  
packing unit: 10 pieces

B	H	S	Ø d	L	Ident-No.
61 [mm]	34 [mm]	2 [mm]	5 [mm]	41,7-45,5 [mm]	180198

152516

## UltraProfiler Blanks HW

Product

Drawing

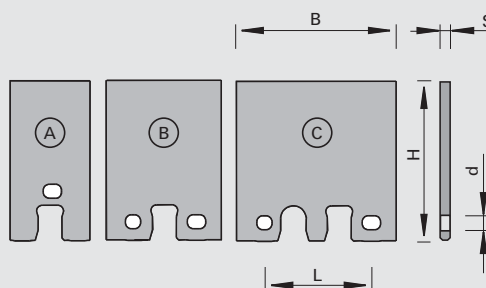
LEUCO  
DUR

tungsten carbide [HW]

Machine / Application

for use in LEUCO UltraProfiler cutterheads

Design

two-point seating and automatic positioning (axial and radial)  
cutting material: HW  
HL Board 06 for wood-based panels, plastics and hard woods

Advantages

precise and automatic positioning of the blanks for profiling and when changing the knives  
no stop screw necessary

Notes

profile knife can be profiled per customer specifications  
packing unit: 10 pieces

B	H	S	Ø d	L	Type	Ident-No.
15	30.4	2	3,5		A	183056
20	40.4	2	3,5		A	183057
25	40.4	2	3,5		A	183058
32	40.4	2	3,5	15,8	B	182419
40	40.4	2	3,5	26,8	C	182420
50	40.4	2	3,5	32,8	C	182421
60	40.4	2	3,5	36,8	C	182422
[mm]	[mm]	[mm]	[mm]	[mm]		

152716

## UltraProfiler Blanks HW

Product

Drawing

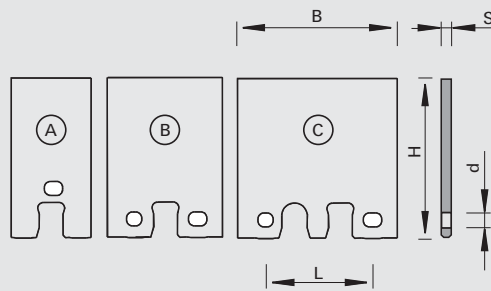
LEUCO  
toplineLEUCO  
DUR

tungsten carbide [HW]

Machine / Application

- for use in LEUCO UltraProfiler cutterheads

Design

- Topline (polished face)
- two-point seating and automatic positioning (axial and radial)
- cutting material: HW
- HL Board 06 for wood-based panels, plastics and hard woods

Advantages

- significantly improved cutting edges
- excellent cutting quality
- precise and automatic positioning of the blanks for profiling and when changing the knives
- no stop screw necessary

Notes

- profile knife can be profiled per customer specifications
- packing unit: 10 pieces

B	H	S	Ø d	L	Type	Ident-No. [L]	Ident-No. [R]
15	30.4	2	3,5		A	183680 o	183680 o
20	40.4	2	3,5		A	183681 o	183681 o
25	40.4	2	3,5		A	183682 o	183682 o
32	40.4	2	3,5	15,8	B	182563	182562
40	40.4	2	3,5	26,8	C	182565	182564
50	40.4	2	3,5	32,8	C	182567	182566
60	40.4	2	3,5	36,8	C	182569	182568
[mm]	[mm]	[mm]	[mm]	[mm]			