

PENTHO COMPACT 4

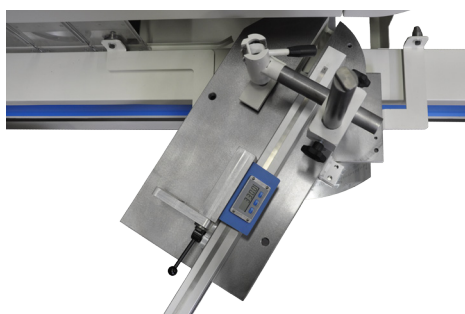

FLEXIBLE AND EASY TO OPERATE TENONER

The Pentho Compact 4 has a noise-reduced cut-off saw, tenon heads and two vertical spindles. The machine has a solid table on a stable vertical slide bar. The depth capacity of the machine is 150 mm. The table can be swivelled totally 60° in two directions. The machine has a dust rejecting transparent safety-screen that moves together with the table and covers the machine completely.



The table can be swivelled 60° in two directions. The working area of the table changes not in shape.



The safety-screen covers the complete machine. Loading and unloading still remains easy.



The spindles are horizontally and vertically adjustable with 0,1 mm accuracy.

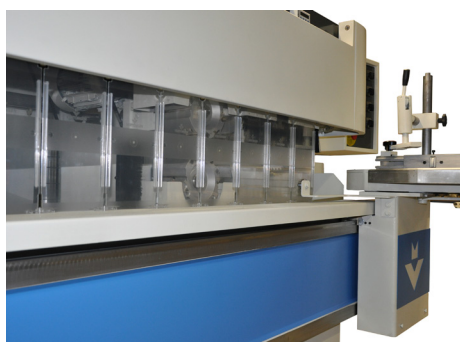
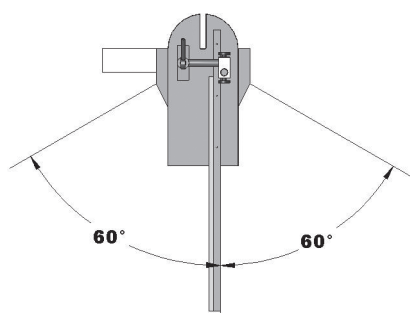

PENTHO COMPACT 4



TECHNICAL DESCRIPTION

CHASSIS

Construction:	ZKF Chassis. Combined self supporting chassis with a cage construction
Safety screen:	Pieces of hard and dust repelling polycarbonate on a rails with wheels. Movement with catch plates.
Security:	Conform CE.
Dimensions:	2730 x 1700 x 1600 mm
Total extraction:	1 x Ø 80 mm; 1 x Ø 150 mm

TABLE

Table mounting:	Vertically attached; extra solid
Movement:	Manually; automatic movement option
Table:	Swivelling +60° to -60°; fixed in height ;
Backing wood:	Clamp for straight backing wood; round backing wood option
Clamps:	quick acting clamp vert.; pneumatic clamps vert. option
Length fence:	2.4 m, 3.4 m optie
Dimensions:	160 mm x 600 mm

CUT OFF SAW

Motor:	2,2 kW - 3000 tpm
Adjustment:	Hor. 20-155 mm - cut-off capacity 150 mm
Tool:	Noise reduced saw included - diam. 400 mm
Extraction:	Diam. 80 mm
Positioning:	Manual on slide bearings
Reading:	Mechanical; laser option

TENONING HEADS

Motor	2 x 2,2 kW
RPM:	4500
Suspension:	Slide bearings
Reading:	Mechanical digital counter on front of machine
Tooling:	Tenon heads included Ø 160 mm; length 145 mm; exchangeable blades
Extraction:	2 x 150 mm diameter
Movement:	Horizontally upper -55 / +25 mm; lower -55 / +0 mm Vertically upper 0 - +150 mm; lower -5 - +115 mm

VERTICAL SPINDLES (2x)

Motor	5,5 kW; 7,5 kW option
RPM:	4000
Suspension:	Dove tail
Reading:	Mechanical digital counter on front of machine
Movement:	Horizontally 150 mm; vertical -150 - +25 mm
Spindle length:	160 mm; 200 mm optie
Spindle Ø:	Ø 40 or Ø 50 mm
Tool Ø:	Max. Ø 350 mm
Extraction:	150 mm diameter

STANDARD



Digital read-out and large swiveling back stop

OPTIONS

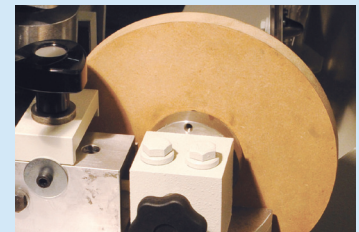

Round backing wood with 6 manual adjustable positions.

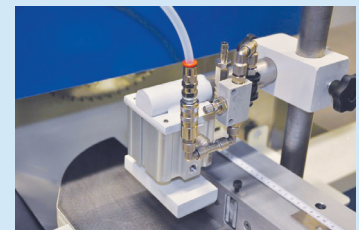

Vertical pneumatic clamp